

Virtu

User Manual Virtu Coffee Machine



**CEC Medium Cabinet
70/90 CoEx[®] brewer**

5DUCEK20I EN V2.3

Preface

Copyright

J.M. de Jong DUKE Automatenfabriek B.V. © 2023.

The contents of this manual are copyrighted. Texts, images, and source files may only be used for professional purposes. No part of this guide may be reused, modified, or published without the prior written permission of the manufacturer. Printing pages is allowed only for professional use.

The English language version is the original version. All other language versions are translations of the original version.

Disclaimer

Although this manual has been put together with the utmost care, J.M. de Jong DUKE Automatenfabriek B.V. accepts no liability for inaccuracies or omissions. No liability is accepted for the consequences arising from operation of the equipment in accordance with the information contained in these instructions. J.M. de Jong DUKE Automatenfabriek B.V. reserves the right to alter specifications at any time and without prior notification to the purchaser.

All rights reserved.

Introduction

- Before using the coffee machine, please read the safety instructions and all of the information in this manual first.
- Keep this manual in a safe and accessible place for later reference.
- The machine serves hot drinks. Keep a distance from the outlet nozzles after selection, during dispense and when the drink is removed from the machine after dispense.
- Only properly trained service personnel may install, move, adjust and repair the machine.
- This machine can be used by children aged 8 years and older and persons with reduced physical, sensory or mental capabilities or lack of experience and knowledge if they have been given supervision or instruction concerning use of the appliance in a safe way and they understand the hazards involved.
- All information for normal daily use is found in the paragraph [Using the coffee machine](#) (on page 32).

- The information in the other paragraphs is meant only for persons trained in the operation and maintenance of the machine.
- Solutions to simple issues or malfunctions that may occur are given in the back of the manual.
- The manual cannot be regarded as a replacement for the training and instruction, but must be seen as an addition to the training, and as a reference work.
- The user manual is valid for the machine supplied by the manufacturer, including the options installed by the manufacturer.
- The manufacturer accepts no liability for any damage resulting from incorrect or improper use of the machine, or resulting from modifications that have not been authorized by the manufacturer.
- Only use original parts from the manufacturer when the machine needs to be repaired.
- Contact the dealer / supplier of the coffee machine (see contact information in the next section) for maintenance or repairs not explained in this manual.

Service and support

For service and support contact the dealer / supplier of the machine.

Record dealer information in this box or use a dealer stamp.

Telephone Service Number:

Internet:

Company name:

Address:

Area code - City:

Country:

Telephone:

E-mail:

Record the serial number of the coffee machine in this box. Mention it when service is required.

Serial number:

Contents

Preface.	2
Copyright.	2
Disclaimer.	2
Introduction.	2
Service and support.	3
About this manual.	8
Audience.	8
Scope.	8
Conventions.	8
Related documents.	9
Availability of this manual.	10
1 Safety.	11
1.1 Safety and risk levels.	11
1.2 Safety and warnings.	11
1.3 Installation.	13
1.4 Maintenance.	13
1.5 Extended down time.	13
2 Description.	14
2.1 Overview.	14
2.1.1 Front view.	15
2.1.2 Inside view.	16
2.1.3 Door interior.	17
2.1.4 Inside view base cabinet — optional.	18
3 User interface.	19
3.1 Display layout.	19
3.2 Main menu - Cup dispensing.	20
3.2.1 Additional options submenu.	22
3.2.2 Jug dispensing submenu.	24
3.2.3 Number selection submenu.	25
3.2.4 Dispense submenu.	27
3.2.5 Ready submenu.	28
3.2.6 Message submenu.	29

3.2.7 Information submenu.	31
4 Using the coffee machine.	32
4.1 Before use.	32
4.2 Procedures.	32
4.2.1 Select a beverage.	32
4.2.1.1 Cup dispensing.	34
4.2.1.2 Cup dispensing by number — optional.	34
4.2.1.3 Jug dispensing.	36
4.2.2 Payment.	39
5 Preventive maintenance.	40
5.1 Food safety engagement.	40
5.2 Preventive maintenance schedule.	41
5.3 Daily maintenance.	42
5.4 Weekly maintenance.	42
5.5 Monthly maintenance.	43
5.6 Preventive maintenance procedures	45
5.6.1 Switch on.	45
5.6.2 Open the door.	45
5.6.3 Close the door.	45
5.6.4 Open or close top lid	46
5.6.5 Switch off / Putting out of order.	46
5.6.6 Scheduled rinse.	47
5.6.7 Flush mixers and brewer.	48
5.6.8 Clean waste bucket.	48
5.6.9 Clean the cup stand.	50
5.6.10 Clean the waste bin in the base cabinet.	51
5.6.11 Clean the drip tray.	54
5.6.12 Clean the mixing system.	55
5.6.13 Remove and clean the brewer.	63
5.6.14 Clean brewer with cleaning tablet.	68
5.6.15 Unblock the grinder.	69
5.6.16 Fill up the cup dispenser — optional.	74
5.6.17 Clean the tea brewer.	75
5.6.18 Clean the canisters.	77
5.6.19 Clean the cold water outlet nozzle — optional.	78
5.6.20 Deep clean the cold water outlet nozzle — optional.	79
5.6.21 Fill up the ingredient canisters.	80
5.6.22 Fill up the bean canister.	83
5.6.23 Enter canister ingredient levels — optional.	86
5.6.24 Clean the outside of the machine.	87
5.6.25 Clean the touchscreen — optional.	87

5.6.26 The service key.	89
5.6.26.1 Insert the service key.	89
5.6.26.2 Remove the service key.	90

6 Troubleshooting. 91

6.1 Messages.	91
6.1.1 Message: Brewer not in home position.	91
6.1.2 Message: Brewer out of position.	91
6.1.3 Message: Clean screen.	91
6.1.4 Message: Cleaning Error.	92
6.1.5 Message: Communication error.	92
6.1.6 Message: Door open.	92
6.1.7 Message: Drip tray full.	92
6.1.8 Message: Empty waste bucket.	92
6.1.9 Message: Enough water?.	93
6.1.10 Message: Filling boiler.	93
6.1.11 Message: Grinder blocked.	93
6.1.12 Message: Heating boiler.	93
6.1.13 Message: Install drip tray.	93
6.1.14 Message: Install waste bucket.	94
6.1.15 Message: Insert coins.	94
6.1.16 Message: Mixer blocked.	94
6.1.17 Message: Machine Blocked.	94
6.1.18 Message: Machine is temporarily out of order.	94
6.1.19 Message: Not all ingredients available.	95
6.1.20 Message: No coffee detected in brewer.	95
6.1.21 Message: No water connected / No water in boiler.	95
6.1.22 Message: Place cup in center.	95
6.1.23 Message: Place cup right.	96
6.1.24 Message: Please load configuration.	96
6.1.25 Message: Please load the User Interface.	96
6.1.26 Message: Replace water filter.	96
6.1.27 Message: Rinse brewer with tablet.	96
6.1.28 Message: Startup problem.	96
6.1.29 Message: Temp. sensor disconnected.	97
6.1.30 Message: Temperature boiler (too) high.	97
6.1.31 Message: Water level too low.	97
6.1.32 Message: Wait, Heating boiler.	97
6.1.33 Message: Waste bucket full / Empty waste bucket.	98
6.1.34 Message: Water filter installed? / Water filter settings not set!.	98

6.1.35 Message: Ready, take your cup.	98
7 Technical specifications.	99
7.1 Standards and regulations.	99
7.2 Type plate.	99
7.3 Disassembly and recycling.	100
7.4 Technical specifications.	101
7.5 Cup and jug sizes.	102
7.6 Manufacturer contact information.	103
8 Appendix.	104
8.1 Appendix list.	104
8.2 Declaration of conformity Virtu.	105

About this manual

Audience

This manual describes how to use and maintain the Virtu coffee machine. Intended users are the end user and staff responsible for regular maintenance of the machine.

De **Jong** DUKE assumes that staff will:

- have sufficient technical knowledge and experience to carry out the tasks assigned to them,
- recognize and prevent possible hazards,
- read and understand this manual,
- follow the procedures described in this manual,
- ensure that the machine will not harm personnel and/or damage its environment.

If the responsible staff has permission to perform maintenance actions or to change parameters, De **Jong** DUKE expects that the operator is trained for these tasks.

Scope

This manual contains essential information for proper operation and maintenance of the machine. Following the instructions contained in this manual should assure trouble-free, safe operation and maintenance of the machine.



CAUTION

Before using or maintaining the machine read this manual carefully to become familiar with the functionality. Make sure that any operator or service engineer understands the correct operating and maintenance procedures and all safety precautions. If any (part of the) information in this manual is unclear contact the supplier.

Operators and service engineers must be adequately trained in the correct operation of the machine. Keep this manual in a pre-determined place near the machine.

Conventions

This manual uses the following text conventions:

- Actions that you should perform in a specific sequence are numbered, for instance, e.g.:
 1. Open the door of the coffee machine.

- Black circled numbers (e.g. 1, 2, 3) and numbers between parentheses e.g. (1) in text refer to elements in a figure.
- Bold text is used for (sub)titles and for information that needs special attention: '**Read these instructions carefully**'.
- Menu names in the user interface are shown in bold, for example: return to the **Main menu**.
- Settings in the user interface are shown in italics; for example: *0.45*.
- Soft keys, keyboard buttons and hardware buttons are shown between brackets, for example: **[Start]**, **[Enter]**, **[2]**.
- Messages shown in the user interface are shown between quotation marks and in italics, e.g.:
'*Place cup right*' (see [Message: Place cup right](#) on page 96).
- Cross-references to sections, tables, figures etc. are indicated as blue text or written as (see "....." on page ..). The main purpose is easy recognition in the paper and on-line (PDF) version of the manual. In the on-line version, the cross-references function as hyperlinks that can be used to navigate through the manual by clicking on them. Example: [Scope](#) (on page 8).
- The safety symbols indicate situations or actions that may endanger the operators and service engineers and are explained in detail in the safety section.
- One additional symbol is available to give the reader additional information:



TIP

Recommendations for the reader.

Related documents

In addition to this manual, the following documentation is available:

- Technical manual
containing all information about the functionality of all parts in the machine, procedures for servicing and configuring the recipes.
- Electrical drawings
contains the electrical drawing/diagrams of the machine.
- Spare parts manual
containing relevant information for identification of the spare parts.
- Third party documentation
contains the available documentation of third-party machine parts.

Availability of this manual

De **Jong** DUKE expects this manual to be available to all operators and service engineers. The original hard copy (paper) version should always be available near the machine.

If the operator has the permission to perform a number of maintenance actions or program activities, De **Jong** DUKE expects that the operator is trained according to the activities and that the appropriate documentation is available for the operator.

Safety

1.1 Safety and risk levels

Four safety and risk levels are used in this manual.

The risk levels and explanations are:

**NOTE**

To show extra information that may help the reader.

**CAUTION**

Indicates a potentially hazardous situation that, if not avoided, can result in minor or moderate injury or damage to the machine or property.

**WARNING**

Indicates a potentially hazardous situation that, if not avoided can result in death, serious injury or machine damage. It includes hazards that are exposed when guards or security features are removed.

**DANGER**

Indicates a hazardous situation that, if not avoided, can result in death or serious injury.

1.2 Safety and warnings

The safety warnings in this section apply to the entire document.

The risk level associated with the explanation are:

**DANGER**

All danger level warnings applicable to the entire document:

- Do not use water in or near the machine unless the instructions contain explicit directions to the contrary. Risk of electrocution when water comes in contact with internal electrical parts.
- Do not use a water jet to clean the coffee machine.

- HOT water! The water system (boiler, pipes, etc.) may contain hot water. Risk of burning when HOT water comes in contact with a person that can cause a scalding injury.
- Do not move, lift or tilt the machine. Risk of serious personal (hand and finger) injuries.
- Only qualified service personnel is allowed access to the internals of the machine.
- Keep the coffee machine and base cabinet locked, even when not in use and store the keys in a safe place.



WARNING

All warning level warnings applicable to the entire document:

- Do not shake the machine while in use. Risk that machine can tip over and fall.
- Do not lean on the door when open. Risk that machine can tip over and fall. Risk of serious injury.



CAUTION

All caution level warnings applicable to the entire document:

- Do not use aggressive cleaning products or abrasives to clean (parts of) the machine.
- Do not use a dish washer to clean parts.
- Do not use a damaged machine. Please contact your supplier.
- If a fault occurs disconnect the machine from the electrical and water supplies. Please contact your supplier immediately.



NOTE

All note level warnings applicable to the entire document:

- Use the machine only in areas where trained personnel can monitor the operation.
- Water and electrical connections must conform to local regulations.
- Make sure a waterlock is used in the water connection.
- If the power cord is damaged it must be replaced by the manufacturer, the supplier or similar qualified persons.
- Do not use an extension cord.
- Do not use an external timing device to manage the availability of the machine.
- Damaged water connection hoses may only be repaired by trained personnel.
- Make sure to follow instructions on all safety labels on and in the coffee machine.
- Do not remove safety labels.

1.3 Installation

For instructions about transportation, unpacking, and installation of the machine, consult the Technical manual.

- Installation, transportation, and adjustment of the machine is specialized work, only properly trained service personnel is allowed to do this.
- The coffee machine is for indoor use only.
- Make sure the machine is placed on a level, flat and stable surface in a hygienic, dry room with a temperature between 41 and 104 °F.
- Make sure that the electricity and water supply connections comply to local regulations and remain easily accessible after installation.

1.4 Maintenance

Regular cleaning is needed to ensure hygienic operation of the machine. This manual explains all cleaning procedures to ensure a proper operation of the coffee machine.

1.5 Extended down time

- If the coffee machine will not be used for a longer period of time (more than one week) it is recommended to turn off the water supply and the electricity (if the power switch is not accessible pulling the main power plug from the wall socket is sufficient). This will also prevent unnecessary use of energy. If the coffee machine was used also check the cleaning procedures in section [Switch off / Putting out of order](#) (on page 46).
- In areas where the temperature can drop below freezing point, the boilers must be emptied. When freezing has occurred allow sufficient time for the machine to reach room temperature before switching on the machine. Contact your supplier (see [Service and support](#) on page 3) for more information.

Description

2.1 Overview

Intended use The Virtu coffee machine is a compact semi-automatic (or fully automatic if a cup dispenser mechanism is included) machine for the preparation and vending of hot (and optionally cold) drinks. The coffee machine is equipped with a paperless CoEx® brewer to make fresh coffee and, depending on the configuration, also espresso.

The coffee machine is operated using the touchscreen panel on the door. By tapping one of the buttons on the screen a product choice can be made. Before a beverage is dispensed a cup or jug must be placed under one of the outlets. More details are found in the sections:

- [Using the coffee machine](#) (on page 32) and
- [User interface](#) (on page 19) for information shown on the touchscreen.

The next sections contain drawings of the front, the inside and the optional base cabinet of the coffee machine. The drawings show the location and the name of the most important parts of the machine.

NOTE

All pictures show a generic configuration. The actual model can be different. To improve clarity, colors in the pictures may be different from the actual colors.

More details are also found in the chapter [Technical specifications](#) (on page 99).

2.1.1 Front view

Front view Virtu (medium model)



NOTE

All pictures show a generic configuration. The actual model can be different. To improve clarity, colors in the pictures may be different from the actual colors.

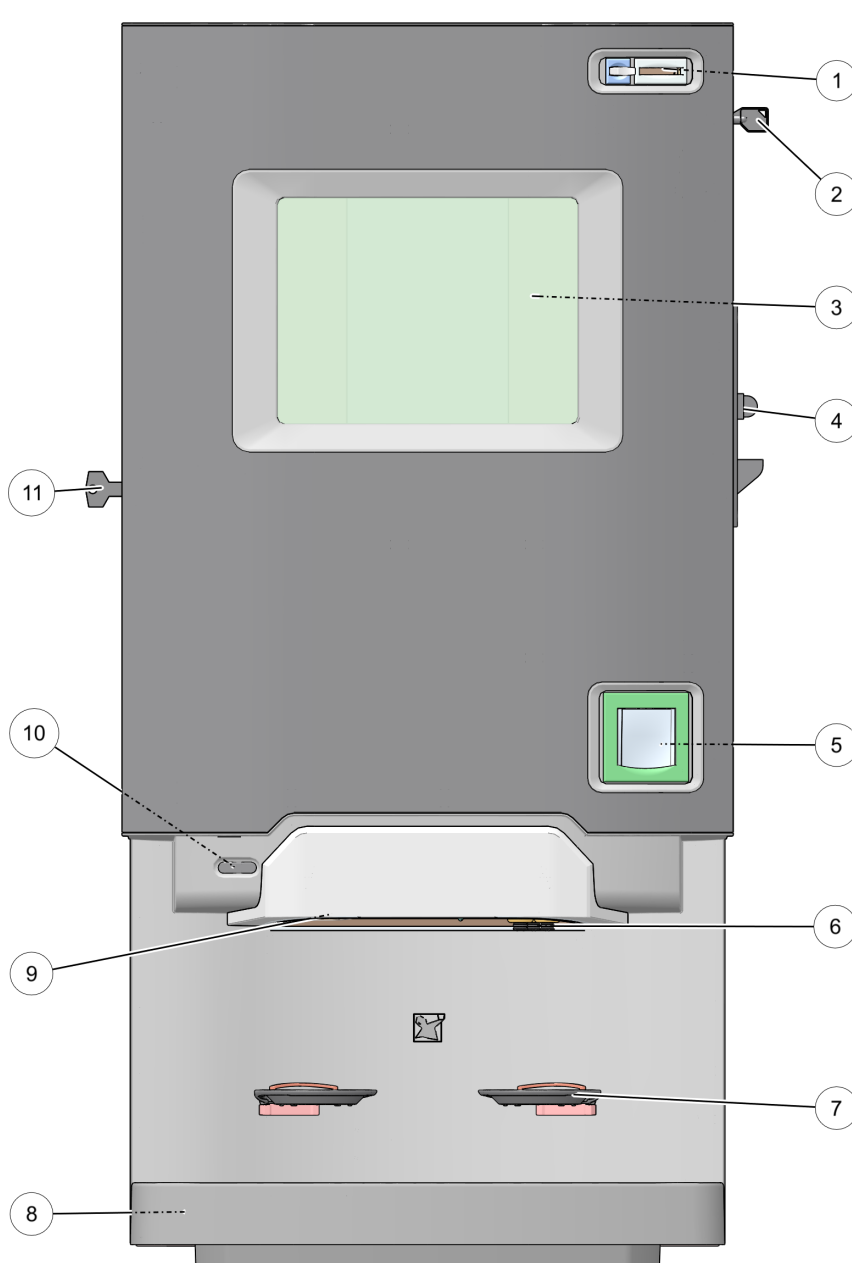

1. Payment system - Change giver coin insert — optional
 2. Jug key — optional
 3. Touchscreen
 4. Payment system - Coin acceptor — optional
 5. Payment system - Change giver coin return — optional
 6. Outlet hot water (/ cold water — optional)
 7. Cup stand (*)
 8. Drip tray / Jug stand
 9. Outlet other dispenses
 10. IrDA sensor — optional
 11. Door lock and key
- *) If the machine contains a cup dispenser, only one cup stand is used and outlets (6 + 9) are centralized.

2.1.2 Inside view

The inside view shows the location and names of the most important parts.



NOTE

All pictures show a generic configuration. The actual model can be different. To improve clarity, colors in the pictures may be different from the actual colors.

Inside view CoEx (medium model)

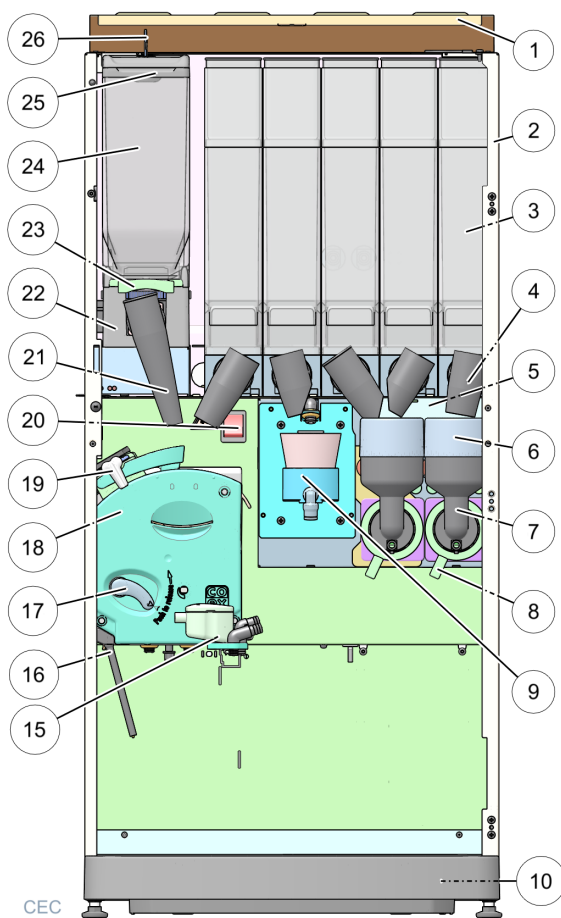

1. Top lid
2. Cabinet
3. Canisters (Ground coffee / Instant / Topping)
4. Canister outlet
5. Exhaust filter drawer
6. Mixer suction trap
7. Mixer house
8. Mixer bayonet catch
9. Tea brewer
10. Drip tray
11. Waste guide to base cabinet -- optional
12. Brewer drip bucket -- option (used with 11)
13. Waste bucket
14. Brewer drip bucket (used with 13)
15. Dispensing nozzles
16. Brewer drip bucket sensor
17. CoEx fixation handle
18. CoEx brewer
19. CoEx brewer outlet
20. Power switch
21. Grinder outlet
22. Grinder
23. Bean canister locking slider
24. Bean canister
25. Bean canister lid
26. Bean canister lid lock -- optional

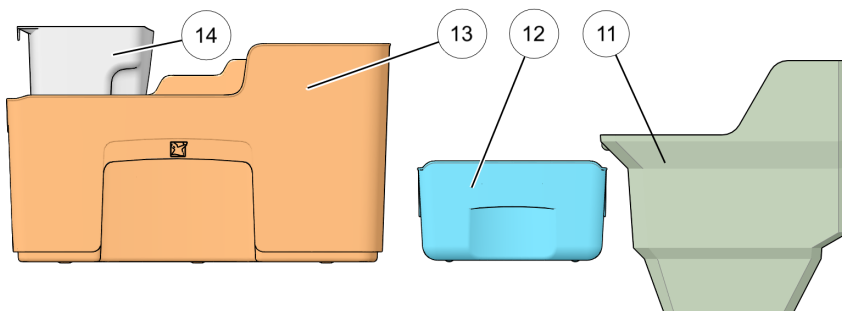

2.1.3 Door interior

Door interior Virtu medium model with optional payment devices (coin acceptor and change giver)



NOTE

All pictures show a generic configuration. The actual model can be different. To improve clarity, colors in the pictures may be different from the actual colors.

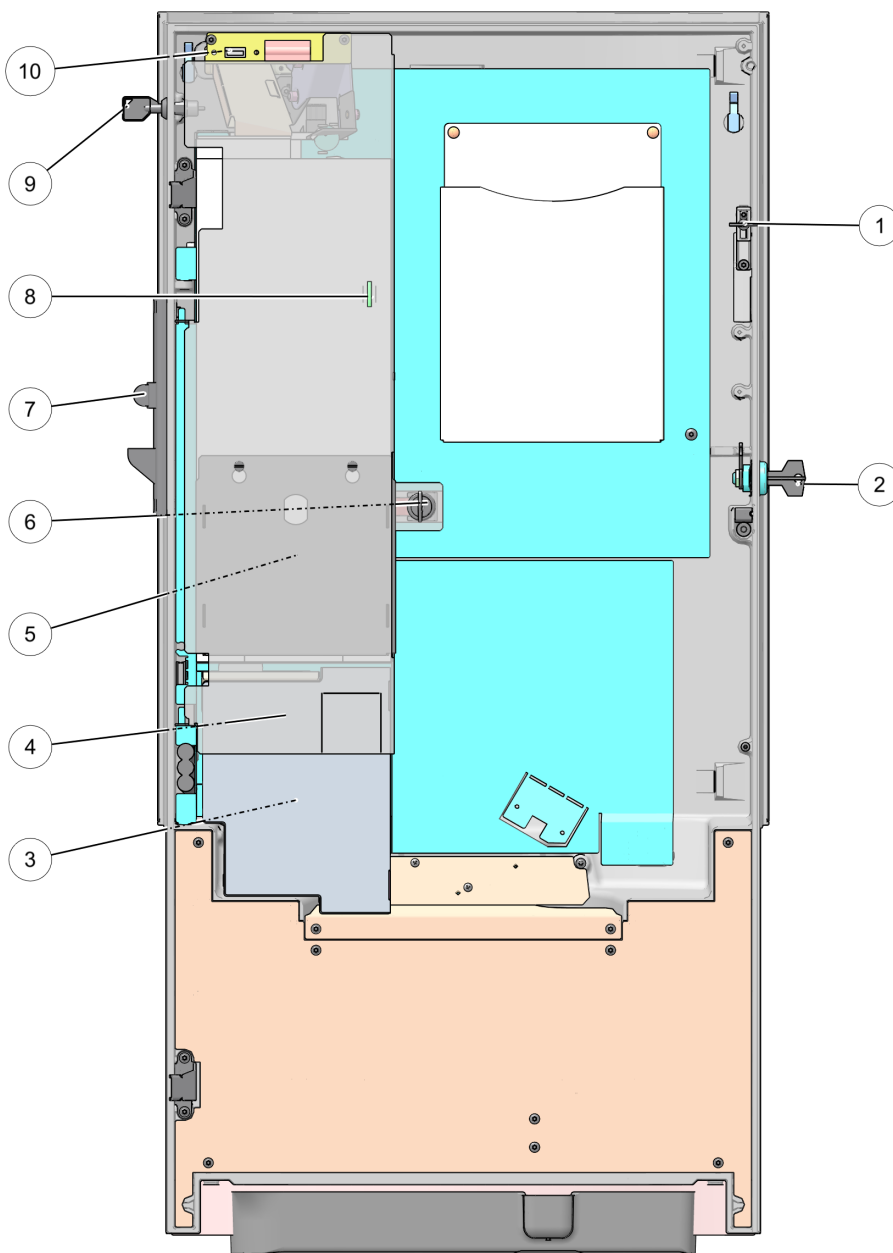

1. Service key entry
2. Door lock and key
3. Coin box for change giver — optional
4. Cover - payment device — optional
5. Coin box - coin acceptor — optional
6. Lock payment device cover — optional
7. Payment device - coin acceptor — optional
8. USB port location without installed payment device
9. Jug key — optional
10. USB port location with installed payment device

2.1.4 Inside view base cabinet — optional

Inside view base cabinet (medium model)



NOTE

All pictures show a generic configuration. The actual model can be different. To improve clarity, colors in the pictures may be different from the actual colors.

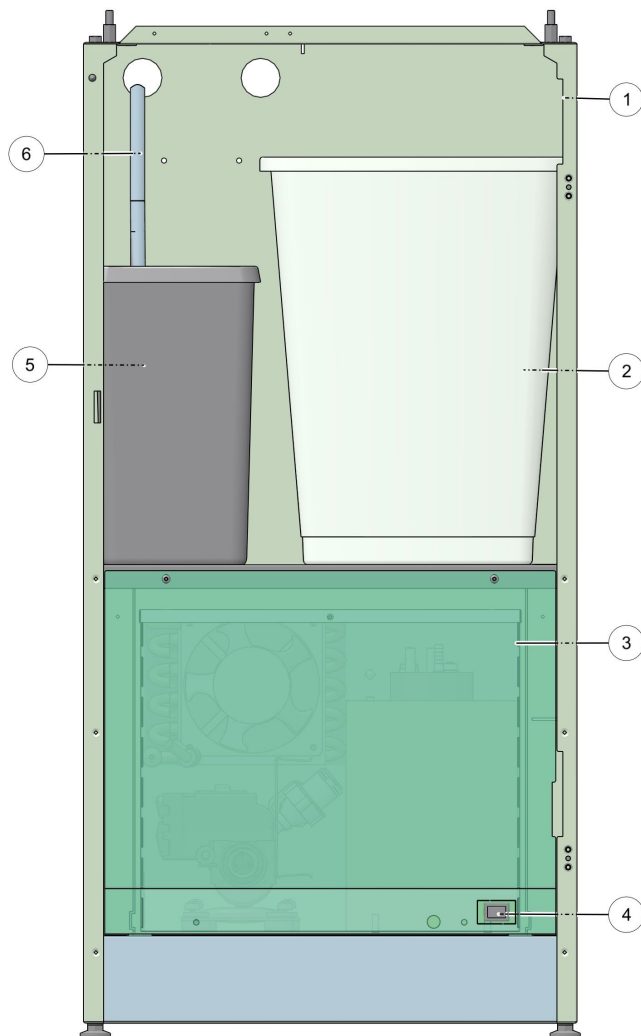

1. Base cabinet
2. Waste bin
3. Chiller sub cabinet -- optional
4. Chiller flush button CO²-- optional
5. Waste water bin
6. Waste water bin sensor -- optional

User interface

3.1 Display layout

The coffee machine is operated with a touchscreen on the door. All selections are made by tapping (a short press) on one of the buttons or menu tabs on the touchscreen.

Main screen layout (example)



NOTE

All drawings and screen images of the coffee machine are based on generic configurations. The actual model will be different but the functionality is similar.

All screens and menus are explained in detail in the next sections. Using the touchscreen to dispense a beverage is explained in the chapter [Using the coffee machine](#) (on page 32).

3.2 Main menu - Cup dispensing

The **Main menu** (or screen) is displayed when the machine is ready for use. It gives access to selections for cup dispensing and all other functions.

Main selection screen

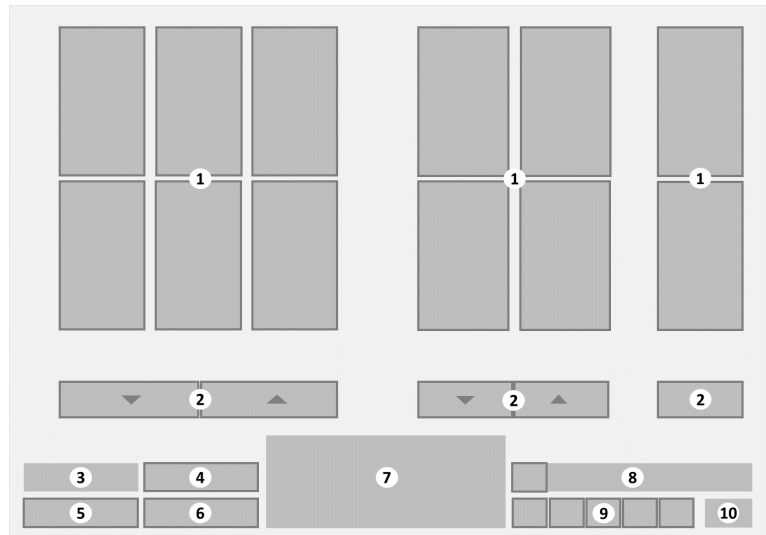

1. **[Cup beverage selections]** buttons
2. **[Scroll up/down]** buttons — optional
3. Credit amount — optional
4. **[Info]** — optional
5. **[Jug]** button — optional
6. **[Number selection]** button — optional
7. Logo — optional
8. Message area
9. **Language menu** buttons — optional
10. Clock — optional

Beverage selection

The main screen shows a selection of the most popular beverages. The available beverages are logically grouped in blocks. When more selections are available than can be displayed in a block, a **[Scroll up/down]** button with an arrow is displayed. Tap this button to show the other available beverage selections. Each beverage button contains a small impression of the beverage, the name and, when payment mode is activated, the price of the beverage. Tap a button to select a beverage.

Lower part of the screen

The lower part of the screen contains at least:

- Message area
Relevant status information about the coffee machine is displayed in the message area. If more than one message must be displayed they are shown in sequence. Tap the **[!]** exclamation mark in front of the message to open the **Message submenu** (on page 29) to see all messages completely. Check the **Message submenu** (on page 29) for more details.
- Clock

Displays the current time (as set in the coffee machine).

Optional Depending on the model and configurations of the coffee machine the following options can be available:

- **Credit amount** — optional
When payment mode is activated, the credit value is displayed. It is the total amount of money already entered for payment of a beverage.
- **[Info]** — optional
Tap the **[Info]** button to open the **Information submenu** (on page 31) with more details about ingredients.
- **[Jug]** — optional
Tap this button to open the **Jug dispensing submenu** (see [Jug dispensing](#) on page 36) with selections to fill complete jugs.
- **[Number selection]** — optional
Tap this button to open the **Number selection submenu** for quick dispense of a beverage.
- **Logo** — optional
- **Language** — optional
If more languages are available the screen shows a selection of language buttons. Tap on the desired language button to change the text on the screen to the selected language.

3.2.1 Additional options submenu

The **Additional options submenu** is displayed after a beverage selection (cup or jug) is made on the **Main menu** (see [Main menu - Cup dispensing](#) on page 20).

- This submenu is not available if the (selected beverage on the) coffee machine is configured for **direct** dispense only.
- The options shown in the submenu depend on the selected beverage, some beverages will have no options at all.
- If a jug dispense is selected, the **[Start]** and **[Cancel]** buttons are available. If canister selection is possible this button bar is displayed.

Additional options submenu

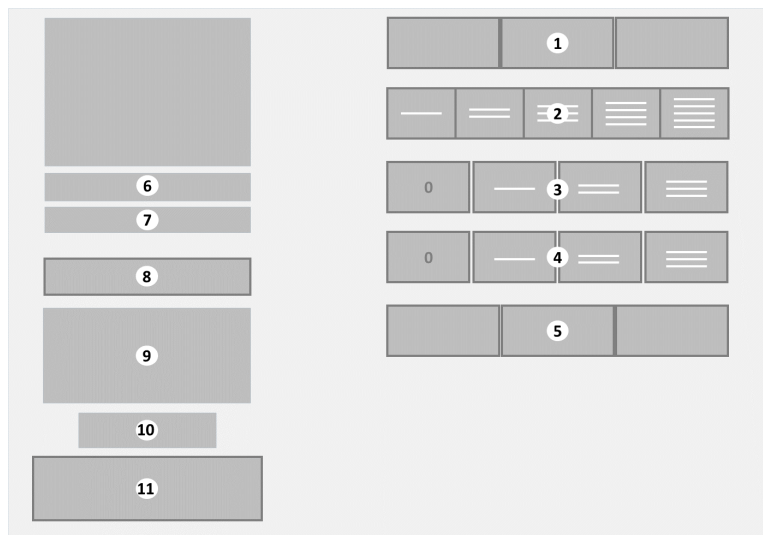

- | | |
|---|--------------------------------|
| 1. [Canister selection] button bar — optional | 7. Currently selected beverage |
| 2. [Strength] button bar — optional | 8. [Cancel] button |
| 3. [Add-on] button bar — optional | 9. Message area |
| 4. [2nd Add-on] button bar — optional | 10. Credit amount — optional |
| 5. [Cup size] button bar — optional | 11. [Start] button |
| 6. Price for this beverage — optional | |

Depending on the configuration additional options are displayed in the submenu. The following options are possible:

- *Canister selection bar*: to select an ingredient from a different canister after initial selection. For example, when coffee is selected, it is then possible to select the type of coffee from different canisters. The current selection is highlighted. Depending on configuration and availability of ingredients, a two or three options bar is shown. Tap the desired canister.
- *Strength selection bar*: to adjust the amount of coffee ingredient. The default strength is the middle button. The selected strength will be highlighted.

- tap a **[LINE]** button for the desired strength. More lines is more strength.
- *Add-on selection bar*: to add an extra ingredient, for example milk, to the selected coffee. The selected amount is highlighted. Tap the desired amount.
 - **[0]** is **no** added ingredient (default).
 - tap a **[LINE]** button for the desired amount of added ingredient. More lines is more ingredient.
- *2nd Add-on selection bar*: to add another extra ingredient, for example sugar, to the selected coffee.
- *Cup size bar*: to select different cup sizes, a two or three options bar can be displayed. The current cup size selection is highlighted. Tap the desired cup size.

The remaining information on the screen:

- Price for the selected beverage. Only visible if payment is activated for the machine.
- The currently selected beverage.
- The **[Cancel]** button. Tap to cancel the current selection and return to the Main menu.
- The Message area. Displays relevant messages of the coffee machine. Tap the **[!] exclamation mark** button to open the [Message submenu](#) (on page 29). Details of all messages and possible solutions to solve simple issues are listed in the section [Messages](#) (on page 91).
- Credit. Displays the amount already entered to pay for the selected beverage. Only visible if payment is activated for the machine.
- The **[Start]** button. Tap this button to start the preparation of the beverage. The button is disabled if no full payment is made or if another problem is found that prevents the dispense. Check the displayed message(s) in the message area.

3.2.2 Jug dispensing submenu

The **Jug dispensing submenu** is displayed after tapping the **[Jug Menu]** button on the **Main menu** (see [Main menu - Cup dispensing](#) on page 20). On some models this menu is only available if the jug function is activated with a pin code.

Jug dispensing menu

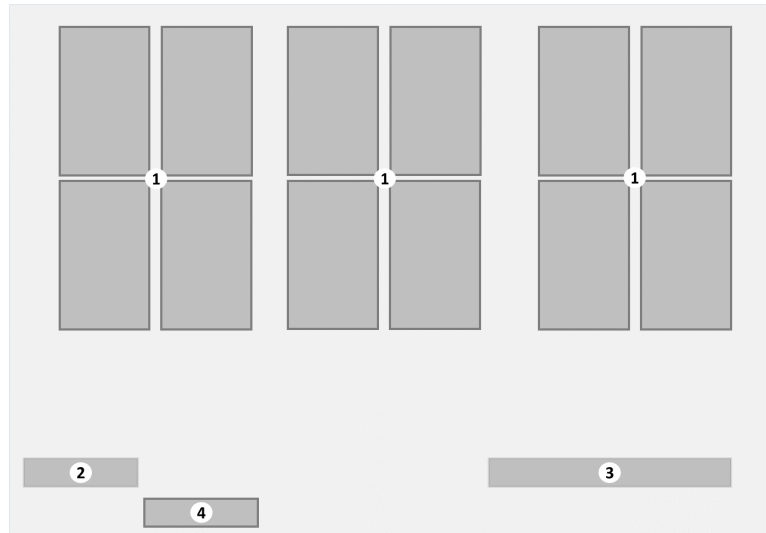

1. **[Jug selection]** buttons
2. Credit amount — optional
3. Message area
4. **[Cup mode]** button

The menu shows the following information:

- The Jug dispensing submenu displays a number of selection buttons with beverages to fill (part of) a jug. Each button contains a small image with an impression of the beverage, the name and, when payment mode is activated, the price of the jug dispense. Tap a button to select a beverage.
- The Message area displays relevant messages of the coffee machine. Tap the **[!] exclamation mark** button to open the [Message submenu](#) (on page 29). Details of all messages and possible solutions to solve simple issues are listed in the section [Messages](#) (on page 91).
- The **[Cup mode]** button. Tap it to cancel the jug selection and return to the Main menu (see [Main menu - Cup dispensing](#) on page 20).

3.2.3 Number selection submenu

The **Number selection submenu** is displayed when the **[Number Selection]** button is tapped on the **Main menu** (see [Main menu - Cup dispensing](#) on page 20).

Number selection menu

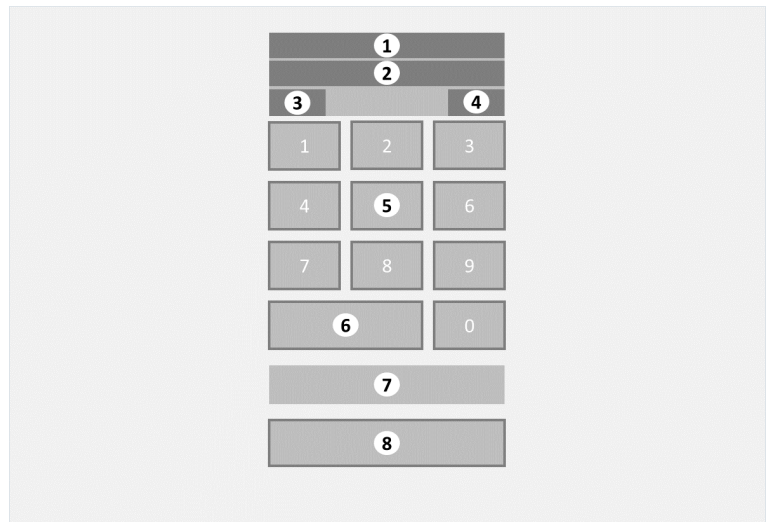

1. Currently entered number selection
2. Actual beverage name
3. Beverage price in payment mode — optional
4. Credit in payment mode — optional
5. Numeric keypad with **[0...9]** buttons
6. **[Cancel]** button
7. Message area
8. **[Start]** button

The display shows the following information:

- The unique number entered for the selected beverage is visible in the small window.
- The actual name connected to the entered number.
- Use the keypad to tap in the **[number selection]** of the desired beverage.



NOTE

The unique number that must be entered here is shown on the **Dispense** menu (see [Dispense submenu](#) on page 27) screen when a beverage is prepared.

- Tap the **[Start]** button to start the preparation and dispense of the beverage.
- Tap the **[Cancel]** button to exit the number selection and return to the **Main** menu.

**NOTE**

If payment is activated for this beverage and the credit amount is smaller than the price of the beverage the **[Start]** button is disabled until full payment has been made. The price for the selected beverage is shown and the credit amount already entered.

- The Message area displays relevant messages of the coffee machine. Details of all messages and possible solutions to solve simple issues are listed in the section [Messages](#) (on page 91).

3.2.4 Dispense submenu

The **Dispense submenu** is shown during preparation and dispense of the beverage.

Dispense submenu



- 1 Progress indicator
2. Beverage name
3. Unique beverage code
4. **[Stop]** button

When the beverage is prepared / dispensed the display shows:

- An impression and/or the name of the beverage currently being prepared.
- An indicator showing the progress of the dispense of the beverage.
- The number displayed is the unique number for the beverage currently prepared. Use this number in the [Number selection submenu](#) (on page 25) — optional for quick dispense of the preferred beverage.
- The **[Stop]** button. Tap it to abort the current dispense and return to the **Main** menu (see [Main menu - Cup dispensing](#) on page 20).

3.2.5 Ready submenu

The **Ready submenu** is shown when the coffee machine is finished with the dispense.

Ready submenu

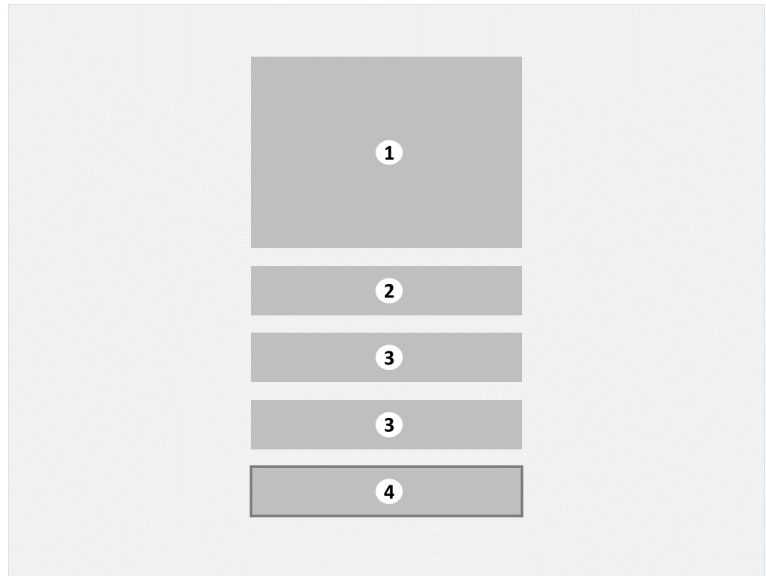

1. Progress indicator
2. Message when dispense is finished
3. Unique number of prepared beverage
4. **[Cancel]** button

When the dispense is completed the display shows:

- A dispense progress indicator at 100% completed.
- The message 'Ready, take your cup' to indicate it is safe to remove the beverage (cup or jug).
- The unique number for the beverage that was prepared. Instead of using the selection and options screens to prepare the preferred beverage this unique number can be entered using the [Number selection submenu](#) (on page 25) — optional.
- The **[Cancel]** button. Tap it or remove the cup/jug to return to the **Main** menu (see [Main menu - Cup dispensing](#) on page 20).

3.2.6 Message submenu

The **Message** submenu shows all relevant messages for this coffee machine in one screen. Tap the **[!]** **exclamation mark** button on any screen to open this [Message submenu](#) (on page 29). Details of all messages and possible solutions to solve simple issues are listed in the section [Messages](#) (on page 91).

Message submenu

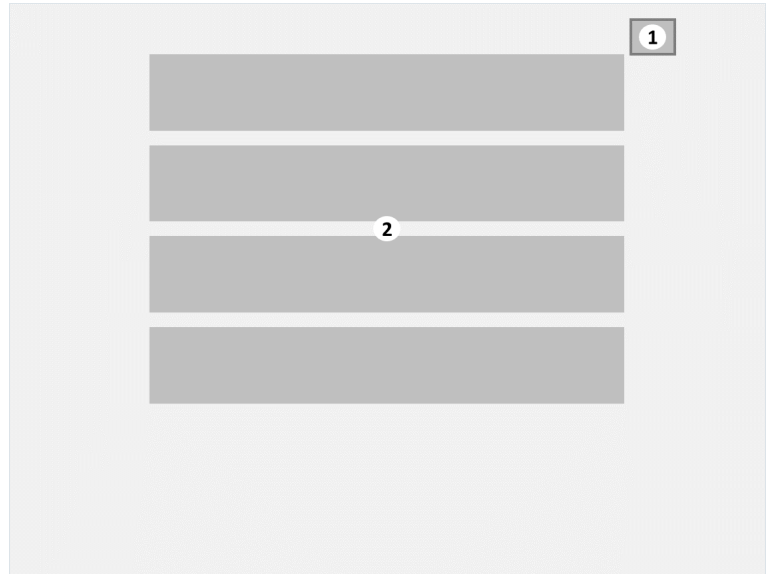

1. **[X]** close button
2. List of all active messages

The message screen displays all active messages from the coffee machine.

- Tap the **[X]** button or tap somewhere in the message area to return to the previous menu.

There are several types of messages

- disable machine messages, e.g. 'Install drip tray' (see [Message: Install drip tray](#) on page 93). When this message is displayed, all selections are disabled and the boiler(s) switched off (for safety reasons). When the drip tray is installed, the boiler(s) are switched on and the selection buttons are enabled.
- disable dispense messages, e.g. 'Insert coins (see [Message: Insert coins](#) on page 94)'. When this message is displayed the coffee machine is fully functional except for the dispense. In this case the **[Start]** button will be enabled after full payment is made.
- disable selections messages, e.g. 'Water level 2 too low'. When this message is displayed some or all beverage selection buttons are disabled. When the boilers are filled and

the water level is correct the message is removed and the selection buttons are enabled.

Details of all messages and possible solutions to solve simple issues are listed in section [Messages](#) (on page 91).

3.2.7 Information submenu

The **Information** submenu is displayed after tapping the **[Info]** button on the **main menu** screen. It shows details about the ingredients or the coffee machine.

Information submenu

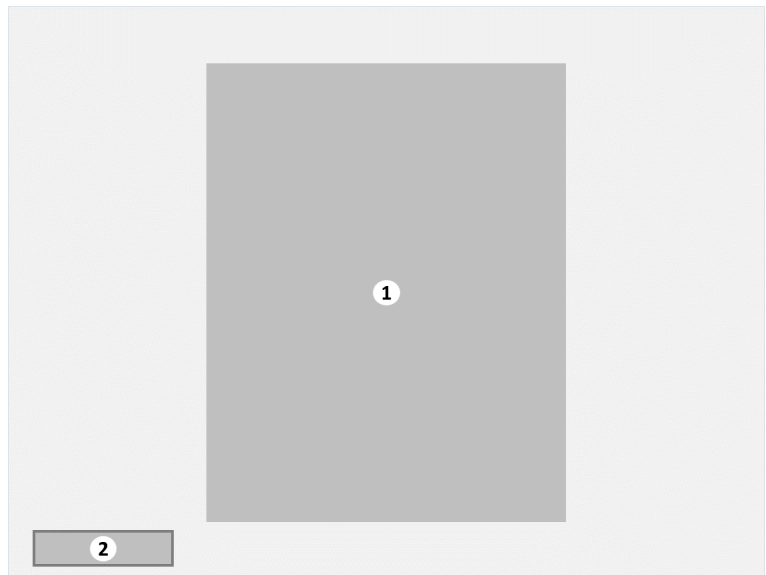

1. Customized information
2. **[Cancel]** button

The customized information image shows details about the beverage or coffee machine and is defined for every available language (for example: Food allergy warnings).

Tap the **[Cancel]** button to return to the **Main menu**.

Using the coffee machine

4.1 Before use

Transportation, installation and adjustment of the machine is specialized work. Only properly trained service personnel should carry this out. Instructions about transportation, unpacking, and installation of the machine can be found in the Technical manual.

- Switch on the coffee machine** Perform the steps described in the procedure [Switch on](#) (on page 45).
- Fill up the ingredient canisters** Perform the steps described in the procedure [Fill up the ingredient canisters](#) (on page 80).

4.2 Procedures

4.2.1 Select a beverage



NOTE

If the **Main menu** (see [Main menu - Cup dispensing](#) on page 20) is not shown, tap on the screen somewhere or place a cup on the cup stand.



NOTE

If the button **[Place cup and press here]** is shown, first perform a rinse procedure (see [Scheduled rinse](#) on page 47).

Procedure

Perform the following steps:

1. Tap the desired **[Language]** button on the screen (optional). The screen will change to the selected language.



TIP

The selected language will remain active until the beverage is dispensed.

2. From the **Main menu** (see [Main menu - Cup dispensing](#) on page 20) select one of the following:

- To fill a single cup using the selection menus continue with the procedure [Cup dispensing](#) (on page 34).
- To (quickly) fill a single cup using pre-set ingredients continue with the procedure [Cup dispensing by number — optional](#) (on page 34).
- To fill (part of) a jug continue with the procedure [Jug dispensing](#) (on page 36).

4.2.1.1 Cup dispensing

Procedure Perform the following steps:

1. Tap the desired beverage button from the selections on the **Main** menu (see on page 20).
 - or first tap one of the **[Scroll Up/down]** buttons and then select the desired beverage.
2. The [Additional options submenu](#) (on page 22) with the selected beverage is shown.
3. When available and needed, tap one or more of the desired options to make additional changes.
4. Place a cup under the correct outlet.
 - check the drawing of the [front view](#) (on page 15) for the correct outlet.
 - if the coffee machine contains a cup dispenser, a cup is automatically placed.
5. Tap the **[Start]** button to prepare the beverage.
 - or tap **[Cancel]** to return to the **Main** menu (see on page 20).
 - when payment mode is activated, full payment is needed first to enable the **[Start]** button. Check the [payment](#) (on page 39) section for more details.
6. The **Dispense** submenu (see on page 27) is now shown and the beverage is prepared.
 - or tap the **[Stop]** button to interrupt and stop the dispense.
7. When the dispense is finished the [Ready submenu](#) (on page 28) is shown.
 - do not remove your cup before the message 'Ready, take your cup (see [Message: Ready, take your cup](#) on page 98)' is visible. The message will remain visible on the screen until the cup is removed.
 - To add an additional beverage to the same cup, do not remove the cup but tap the **[Cancel]** button and select the next beverage.
8. The prepared drink is ready.



WARNING

Hot liquid can leak from the outlet nozzle after the dispense is finished.

4.2.1.2 Cup dispensing by number — optional

Each beverage with specific strength and/or added ingredients has its own code. Instead of entering all selections, this code can be used to dispense the beverage more quickly with required strength and additional ingredients.

**NOTE**

This procedure is optional and only available if the **[Number Selection]** button is available on the **Main menu**.

Procedure Perform the following steps:

1. Tap the unique **[number]** of the desired beverage on the keypad displayed on the screen.

**NOTE**

The actual number that needs to be entered here is shown on the **Dispense** menu (see [Dispense submenu](#) on page 27) screen when the beverage is prepared / during dispense.

2. Tap the **[Start]** button to prepare the beverage.
 - or tap **[Cancel]** to return to the **Main** menu (see on page 20).
 - when payment mode is activated, full payment is needed first to enable the **[Start]** button. Check the [payment](#) (on page 39) section for more details.
3. The **Dispense** submenu (see on page 27) is now shown and the beverage is prepared.
 - tap the **[Stop]** button to interrupt and stop the dispense.
4. When the dispense is finished the [Ready submenu](#) (on page 28) is shown.
 - do not remove your cup before the message 'Ready, take your cup (see [Message: Ready, take your cup](#) on page 98)' is visible. The message will remain visible on the screen until the cup is removed.
 - To add an additional beverage to the same cup, do not remove the cup but tap the **[Cancel]** button and select the next beverage.
5. The prepared drink is ready.

**WARNING**

Hot liquid can leak from the outlet nozzle after the dispense is finished.

4.2.1.3 Jug dispensing

Purpose When configured it is possible to fill complete jugs at once.

Procedure Perform the following steps:

WARNING

The outlet of the machine may occasionally drip hot liquid even when the machine is not in use.

When hot liquid comes in contact with a person, this can lead to serious scalding injuries.

If the coffee machine is provided with a cup dispenser the door contains one central cup stand (**F**-fully automatic) for beverages and water dispense. If the door of the coffee machine contains two cup stands the user places the cup on the correct cup stand depending on the beverage selection (**H**-half automatic).

1. Place the cup stand(s) in the upright position.

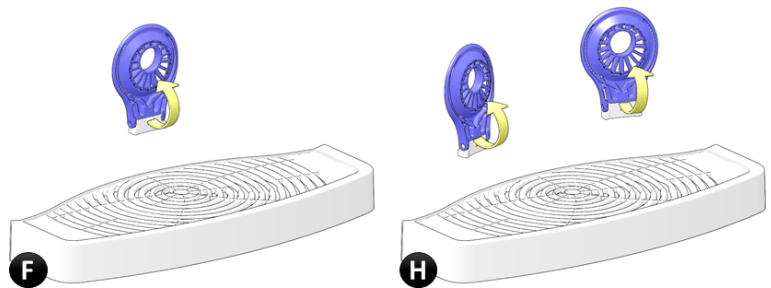

2. For hot (or cold water - optional) water: on a machine with one cup stand (F) place the jug in the **middle**. On a machine with two cup stands (H) place the jug on the **right** side below the hot water outlet.



WARNING

If jugs are not correctly placed, the machine can spill hot liquid down the front. This can cause serious scalding injuries.

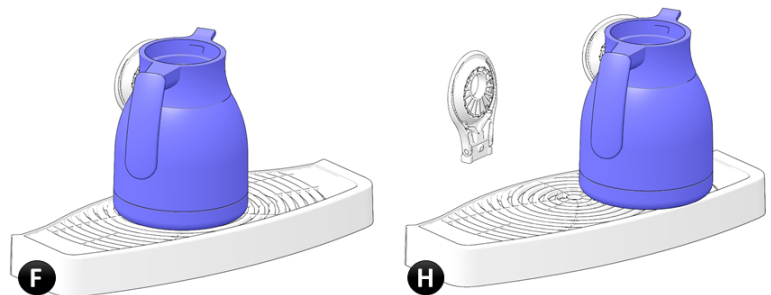

3. For all other dispenses: on a machine with one cup stand (F) place the jug in the **middle**. On a machine with two cup

stands (H) place the jug on the **left** side below the main outlet.

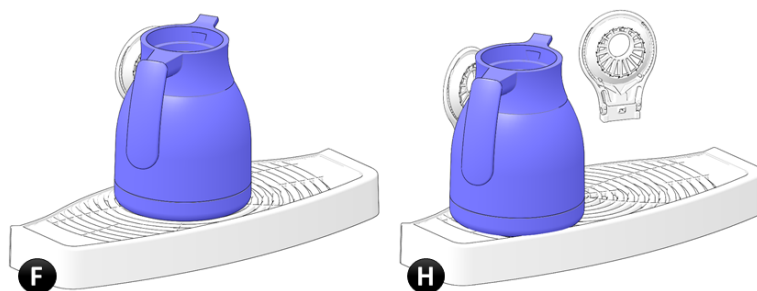

4. If the jug submenu is not visible tap the **[Jug]** button from the main menu (see [Main menu - Cup dispensing](#) on page 20).
5. Tap the desired beverage and jug filling from the shown selection buttons.
 - or tap the **[Cup mode]** button to return to the **Main menu**
6. Tap the **[Start]** button to start the dispense.
 - tap the **[Cancel]** button to return to the **Main menu** (see [Main menu - Cup dispensing](#) on page 20).
 - when payment mode is activated, full payment is needed first to enable the **[Start]** button. Check the [payment](#) (on page 39) section for more details.
 - if the **[Start]** button is disabled check the Message area for more details.
7. The Dispense submenu (see [Dispense submenu](#) on page 27) is now displayed.
 - tap the **[Stop]** button to interrupt and stop the dispense.
8. When the dispense is finished the [Ready submenu](#) (on page 28) is shown.
 - do not remove your cup/jug until the message "*Ready, take your cup*" (see [Message: Ready, take your cup](#) on page 98) " is shown.
 - the message will remain visible on the screen until the cup/jug is removed.
 - to add an additional beverage to the **same** cup/jug tap the **[Cancel]** button.



CAUTION - Hot liquid can leak from the outlet nozzle after the dispense is finished.

9. The filled jug is ready.
10. Pull down the cup stands to the original position.

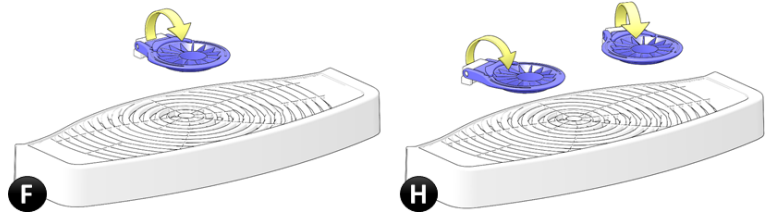

4.2.2 Payment

Purpose If the coffee machine is activated for payment, the cup or jug dispense will only start after full payment is made.

Procedure Perform the following steps:

1. The *price* for the dispense of the selected cup / jug is shown on the screen.
2. Make the full payment.
 - The entered *credit* amount is calculated and shown on screen.



NOTE

The **[Start]** button will remain disabled until full payment is made.

Preventive maintenance

5.1 Food safety engagement

Food safety and quality are important for both customer and those who work in the vending industry. Respecting a number of basic principles, such as personal hygiene, is essential. We therefore advise you to follow the advice given in "A hygiene guide for vending". This guide is published by the European Vending and Coffee Association and has been prepared to help ensure that a hygienic product is delivered to the customer on every occasion.

5.2 Preventive maintenance schedule



NOTE

Skipping maintenance can affect the quality of the dispensed drink and may lead to malfunctioning of the machine. Clean the coffee machine at the end of the day and before the machine is switched off for a longer period.

The schedule below gives an overview of all procedures needed to maintain the coffee machine.

Preventive maintenance schedule CoEx (XL) brewer (medium model)

Cleaning procedures for the coffee machine with intervals	D	W	M	H
Scheduled rinse (on page 47)	X			
Flush mixers and brewer (on page 48)	X			
Clean the mixing system (on page 55)		X		
Clean the tea brewer (on page 75) — optional		X		
Remove and clean the brewer (on page 63)		X		
Clean brewer with cleaning tablet (on page 68)		X		
Clean waste bucket (on page 48)	X			
Clean the drip tray (on page 54)	X			
Clean the cup stand (on page 50)	X			
Clean the waste bin in the base cabinet (on page 51)		X		
Clean the cold water outlet nozzle — optional (on page 78)		X		
Deep clean the cold water outlet nozzle — optional (on page 79)			X	
General Cleaning cold water system ⁽¹⁾				X
Sanitization cold water system ⁽¹⁾				X
Fill up the cup dispenser — optional (on page 74)	X			
Clean the canisters (on page 77)			X	
Fill up the ingredient canisters (on page 80)	X			
Enter canister ingredient levels — optional (on page 86)	X			
Clean the outside of the machine (on page 87)	X			
Clean the touchscreen — optional (on page 87)	X			

⁽¹⁾ Cold water specific cleaning procedures must be performed by a certified dealer and are not explained in this end user manual.

Interval column codes	D	W	M	H
Daily	D			
Weekly		W		
Monthly			M	
Every 6 months				H



NOTE

If the coffee machine dispenses more than 250 coffee related



beverages every day, the brewer should be cleaned with a cleaning tablet every other day.

5.3 Daily maintenance

Purpose Performing daily maintenance will ensure the quality of your beverages and a proper operation of the machine.

Procedure For daily maintenance follow these steps:

1. [Open the door](#) (on page 45) of the machine.
2. [Flush mixers and brewer](#) (on page 48).
3. [Clean waste bucket](#) (on page 48).
4. [Clean the drip tray](#) (on page 54).
5. [Clean the cup stand](#) (on page 50) in the door.
6. [Clean the waste bin in the base cabinet](#) (on page 51).
7. Fill up the cup dispenser (see [Fill up the cup dispenser — optional](#) on page 74)
8. [Fill up the ingredient canisters](#) (on page 80).
9. [Enter canister ingredient levels — optional](#) (on page 86).
10. [Close the door](#) (on page 45).
11. [Clean the outside of the machine](#) (on page 87).
12. [Clean the touchscreen — optional](#) (on page 87)
13. Check correct functioning by taking a test beverage.

Each step is described in detail in the next sections.

5.4 Weekly maintenance

Purpose Performing weekly maintenance will ensure the quality of your beverages and a proper operation of the machine.

Procedure For weekly maintenance follow these steps:

1. [Open the door](#) (on page 45) of the machine.
2. [Clean the mixing system](#) (on page 55).
3. [Clean the tea brewer](#) (on page 75) — optional
4. [Remove and clean the brewer](#) (on page 63).
5. [Clean brewer with cleaning tablet](#) (on page 68).
6. [Clean waste bucket](#) (on page 48).
7. [Clean the drip tray](#) (on page 54).
8. [Clean the cup stand](#) (on page 50) in the door.
9. [Clean the waste bin in the base cabinet](#) (on page 51).
10. [Clean the cold water outlet nozzle — optional](#) (on page 78).
11. Fill up the cup dispenser (see [Fill up the cup dispenser — optional](#) on page 74)

12. [Fill up the ingredient canisters](#) (on page 80).
13. [Enter canister ingredient levels — optional](#) (on page 86).
14. [Close the door](#) (on page 45).
15. [Clean the outside of the machine](#) (on page 87).
16. [Clean the touchscreen — optional](#) (on page 87).
17. Check correct functioning by taking a test beverage.

Each step is described in detail in the next sections.



NOTE

If the coffee machine dispenses more than 250 coffee related beverages every day, the brewer should be cleaned with a cleaning tablet every other day.

5.5 Monthly maintenance

Purpose Performing monthly maintenance will ensure the quality of your beverages and a proper operation of the machine.

- Procedure** For monthly maintenance follow these steps:
1. [Open the door](#) (on page 45) of the machine.
 2. [Clean the mixing system](#) (on page 55).
 3. [Clean the tea brewer](#) (on page 75) — optional
 4. [Remove and clean the brewer](#) (on page 63).
 5. [Clean brewer with cleaning tablet](#) (on page 68).
 6. [Clean waste bucket](#) (on page 48).
 7. [Clean the drip tray](#) (on page 54).
 8. [Clean the cup stand](#) (on page 50) in the door.
 9. [Clean the waste bin in the base cabinet](#) (on page 51)
 10. [Deep clean the cold water outlet nozzle — optional](#) (on page 79).
 11. Fill up the cup dispenser (see [Fill up the cup dispenser — optional](#) on page 74)
 12. [Clean the canisters](#) (on page 77).
 13. [Fill up the ingredient canisters](#) (on page 80).
 14. [Enter canister ingredient levels — optional](#) (on page 86).
 15. [Close the door](#) (on page 45).
 16. [Clean the outside of the machine](#) (on page 87).
 17. [Clean the touchscreen — optional](#) (on page 87).
 18. Check correct functioning by taking a test beverage.

Each step is described in detail in the next sections.



NOTE

If the coffee machine dispenses more than 250 coffee related



beverages every day, the brewer should be cleaned with a cleaning tablet every other day.

5.6 Preventive maintenance procedures

5.6.1 Switch on

Procedure Perform the following steps:

1. Turn on the water supply.
2. Connect the power cord to an earthed power socket.
3. [Open the door](#) (on page 45).
4. Switch the **[ON/OFF]** power switch to the *ON* position.
 - check the drawing of the [inside view](#) (on page 16) for the precise location.
5. [Close the door](#) (on page 45).
6. The coffee machine will start up.
7. The main screen is displayed with the message '*Filling boiler*' and then '*Heating boilers*' in the *User message area* (see [Additional options submenu](#) on page 22).



NOTE

If the door was left open for too long the **Service menu** is shown. Tap the **[Exit]** button and then the **[Close door and press here to quit service]** button to leave the **Service menu**.

8. After a few minutes the message '*Heating boilers*' disappears and the machine is ready for use.

5.6.2 Open the door

Procedure Perform the following steps:

1. Insert the **key** in the lock of the door of the coffee machine.
2. Turn the **key** 90 degrees.
3. Open the door.
 - The **Service menu** is displayed on the screen.



NOTE

Do not leave the door open unattended to prevent unauthorized access to the inside of the machine.

5.6.3 Close the door

Procedure Perform the following steps:



WARNING

Make sure all canisters are installed.

1. Insert the **key** in the lock of the door of the coffee machine.
2. Turn the **key** 90 degrees.
3. Close the door.
4. Turn the **key** 90 degrees to lock the door.
5. Remove the **key** and store it in a safe place.



NOTE

Always remove the key from the coffee machine and optional base cabinet to prevent unauthorized opening of the door.

6. (Optional) To leave the **Service menu**: Tap the **[Exit]** button and then the **[Close door and press here to quit service]** button to leave the **Service menu**.

5.6.4 Open or close top lid

Purpose

To fill up or clean the canisters they need to be removed from the coffee machine. To allow easy access to the canisters, the top lid of the coffee machine can be opened.

NOTE

The top lid locks inside the door and can only be opened if the door is opened. Depending on the model, the top lid can contain cut outs for one or two (bean) canisters.

Procedure

Perform one of the following steps:

1. To open, lift the top lid in the front and swing it open to the back. The top lid stays open in the upright position.
2. To close, swing the opened top lid back down. Make sure it is lowered completely and locks when the door is closed.

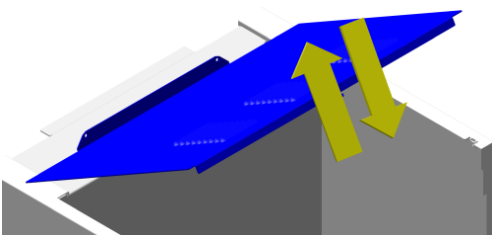

5.6.5 Switch off / Putting out of order

Procedure

Perform the following steps:

1. [Open the door](#) (on page 45).
2. Switch the **[ON/OFF]** power switch to the *OFF* position.

- check the drawing of the [inside view](#) (on page 16) for the precise location.
- If the coffee machine is not used for a longer period of time (more than one week) it is recommended to:
 - perform [daily maintenance](#) (on page 42) or, if the machine is not used for a longer time, it is recommended to perform [monthly maintenance](#) (on page 43).
 - turn off the water supply.
 - switch off the power supply (pulling the plug from the wall socket is sufficient). This will also prevent unnecessary use of energy.

Also see section [Extended down time](#) (on page 13).

5.6.6 Scheduled rinse

Purpose Cleaning the coffee machine can be skipped or forgotten. The scheduled rinse is forced every day using a scheduler. When activated follow the procedure below to perform the rinse. Instead you can also run the [daily maintenance](#) (on page 42) or [weekly maintenance](#) (on page 42).

Required Use the following parts to perform the procedure:

- A rinsing tub or 1 liter jug

Interval Perform this procedure:

- Daily (see [Daily maintenance](#) on page 42), announced on screen

Procedure Perform the following steps:

1. Place a rinsing tub or jug under the outlet nozzle to collect the rinse water.
2. Tap the button **[Place cup and press here]** on the screen.
 - Hot water from the boiler flows through the mixers and brewer.
3. A progress screen is shown.
 - Wait until the rinse procedure is finished.
 - Total time to rinse is 1 to 2 minutes.
4. Remove the rinsing tub.
5. The machine returns to the **Main menu** (see [Main menu - Cup dispensing](#) on page 20) and is ready for use.

5.6.7 Flush mixers and brewer

- Purpose** The Rinse process flushes hot water through the mixers and the brewer to remove any residue.
- Required** Use the following parts to perform the procedure:
- Rinsing tub.
- Interval** Perform this procedure:
- At least Daily (see [Daily maintenance](#) on page 42), more if needed.
- Total time**
- Total time needed to rinse is 1 to 2 minutes.
- Procedure** Perform the following steps:
1. If needed [Open the door](#) (on page 45) to show the service menu on the touch screen.
 2. [Close the door](#) (on page 45).
 3. Place a rinsing tub underneath the outlet nozzle to collect the hot waste water.
 4. Tap the **[Maintenance]** button and then the **[Daily Cleaning Cycle]** button from the **Service** menu.
 - Hot water from the boiler flows through the mixers and brewer.
 5. Repeat the previous step until clean water comes out of the machine.

5.6.8 Clean waste bucket

- Purpose** After every dispense the coffee residue (so called coffee cakes) are moved into the waste bucket. Excess water from the brewer is captured in a drip bucket placed inside the waste bucket just below the brewer. If an external waste bin is used, the waste bucket is replaced by a waste guide.
- Interval** Perform this procedure:
- Daily (see [Daily maintenance](#) on page 42)
- Procedure** Perform the following steps:

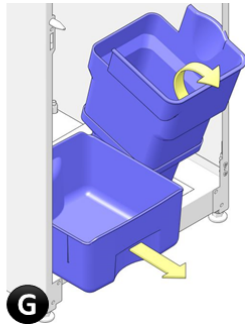
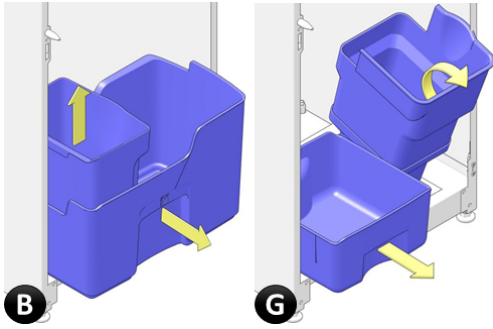

1. Depending on the used bucket types:
 - B) Remove the waste bucket (with the drip bucket inside it) from the machine, or
 - G) Remove the drip bucket and the waste guide from the machine.
2. Rinse the removed parts with clean warm water.
3. Dry parts completely.

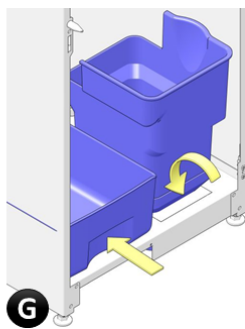
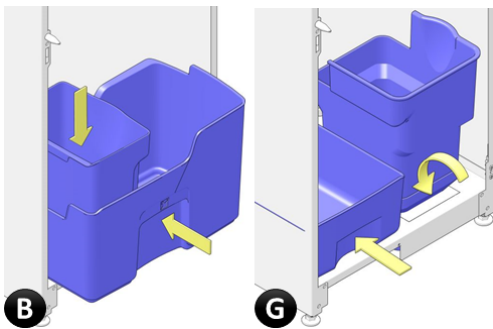

4. Install the waste buckets.
 - B) Place the drip bucket inside the waste bucket and install both inside the machine, or
 - G) Place the drip bucket on the left and the waste guide on the right side in the machine.

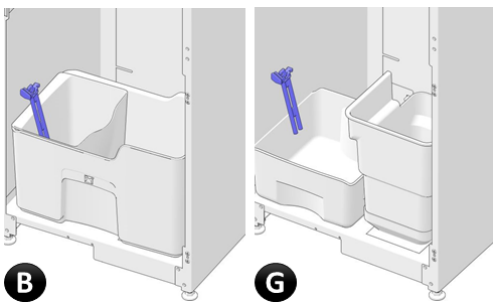

5. Make sure the water level sensor is placed **inside** the drip bucket.

5.6.9 Clean the cup stand

Purpose To clean the cup stands they must be removed from the machine.



NOTE

Depending on the model, the coffee machine contains one or two cup stands.

Interval Perform this procedure:

- Daily (see [Daily maintenance](#) on page 42).

Procedure Perform the following steps to remove the cup stands:

1. Hold the cup stand and pull one leg from the hinge pin.

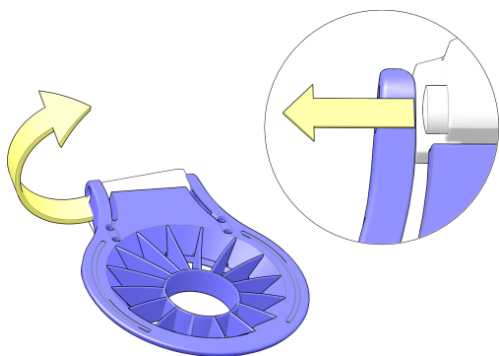

2. Lift one side slightly and move the other leg of the cupstand in the direction of the arrow to release it from the other hinge pin.
3. If needed, repeat the steps to remove the other cup stand.
4. Rinse all removed items with clean warm water.

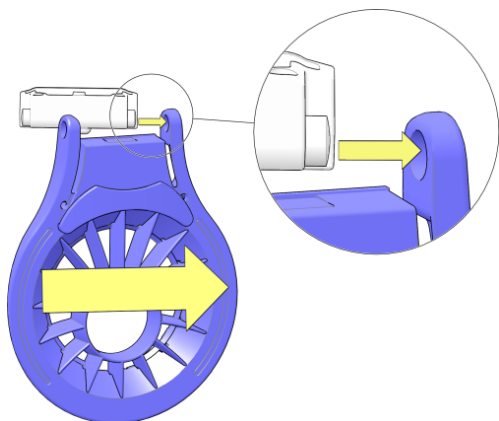

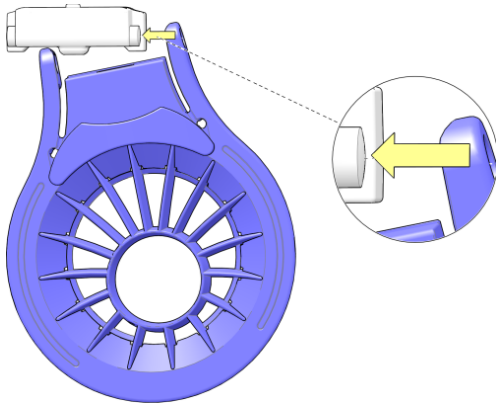

5. To install, place one leg of the cup stand on the hinge pin in the door.

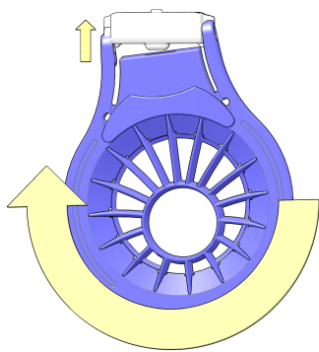

6. Turn the cup stand towards the other hinge pin and push the leg with a little force onto it.

7. Repeat the last steps to install the other cup stand.

5.6.10 Clean the waste bin in the base cabinet

Purpose If waste bins in a base cabinet (or other external cabinet) are installed, excess water from the brewer and waste water from the drip tray is captured in the left waste bin and coffee residue in the right waste bin. Both must be cleaned regularly.

Interval Perform this procedure:

- Weekly (see [Preventive maintenance schedule](#) on page 41) or more if needed.

Procedure Perform the following steps:

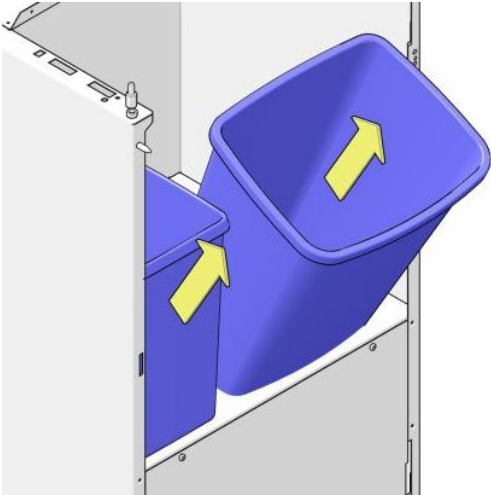

1. Remove the waste bin(s) from the base cabinet.
2. Rinse the removed bin(s) with clean warm water.
3. Dry the bin(s) completely.

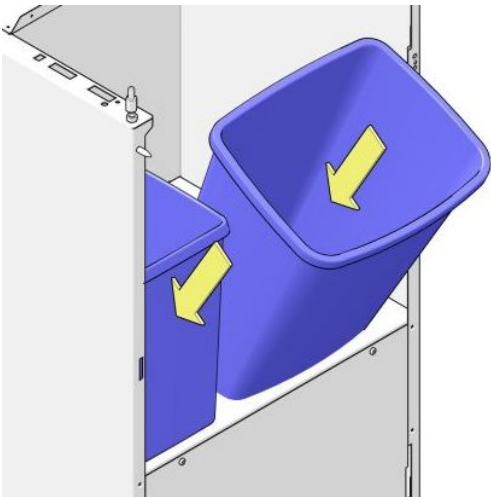

4. Place the waste bin(s) in the base cabinet.

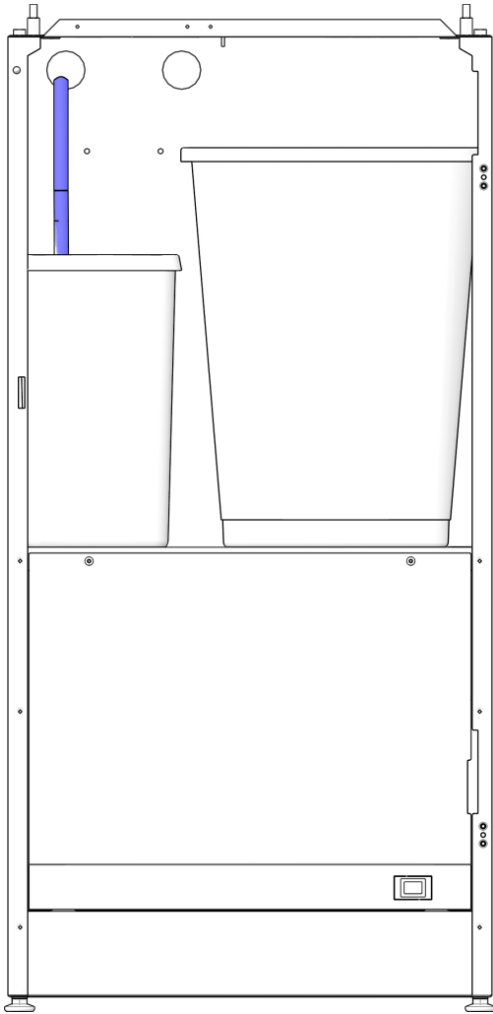

5. When used, make sure that the waste water level sensor is placed inside the left waste bin.
6. If the coffee machine displays the message '*Waste bucket full / Empty waste bucket*', tap the **[Maintenance]** button in the Service menu and then the **[Reset waste bin]** button to reset the counter and remove the message.

5.6.11 Clean the drip tray

Purpose The drip tray collects waste water from the coffee machine and waste water during the dispense of products and must be cleaned regularly. The drip tray is covered by the jug stand. Depending on the model, the jug stand can contain a metal inlay grid.

Interval Perform this procedure:

- Daily (see [Daily maintenance](#) on page 42).



NOTE

If the drip tray is connected to a larger waste bucket/bin or directly to the main waste water disposal the cleaning interval can be lowered to once a week.

Procedure Perform the following steps:

1. Lift the jug stand at the front and remove it from the support guides in the door.
 - Depending on model the jug stand can contain a metal inlay that must be removed too.



NOTE

For clarity reasons the cup stands are not shown in the picture.

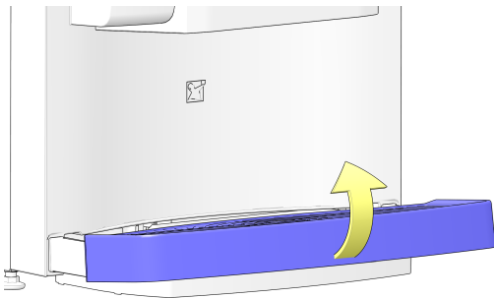

2. Pull the drip tray in the direction of the arrow and remove it from the machine.
3. Rinse all removed items with clean warm water.
4. Dry all items.

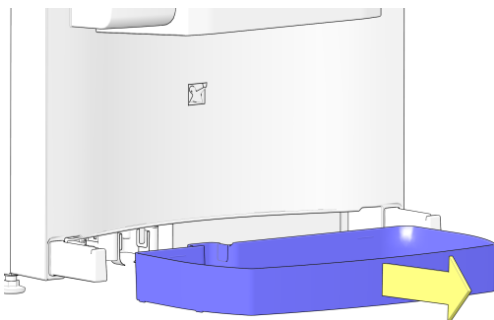

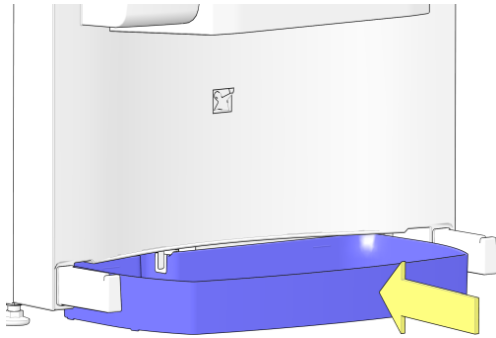

5. Place the drip tray.

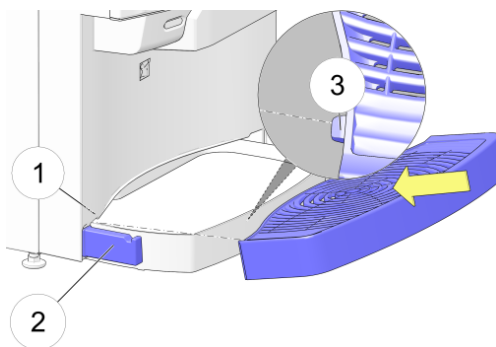

6. Place the jug stand on the guides (2) and slide it in the direction of the arrow.



NOTE

Make sure that the ledges on the back of the jug stand (3) fit inside the notches in the door (1).

7. Push the jug stand down to secure it properly to the door and the support guides (2).

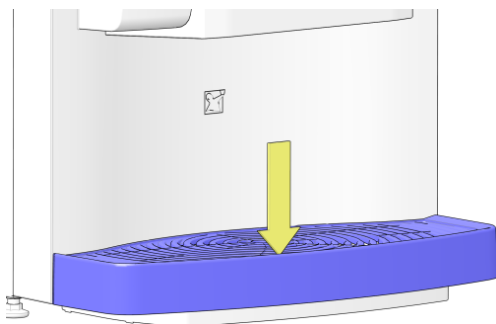

8. Depending on the model: place the metal inlay grid.

5.6.12 Clean the mixing system

Purpose To prevent clogging of ingredients the mixers must be removed from the coffee machine and cleaned.

Interval Perform this procedure:

- Weekly (see [Weekly maintenance](#) on page 42), increase the frequency if needed

Procedure Perform the following steps:

1. Remove the outlet hoses from the mixers.

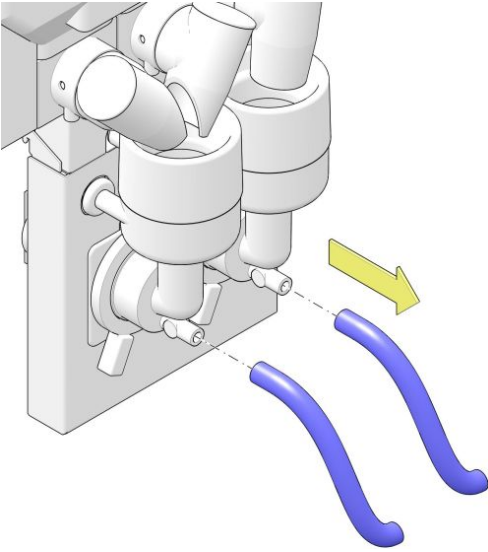

2. Remove the canister outlets and remember the correct position and location of each outlet.

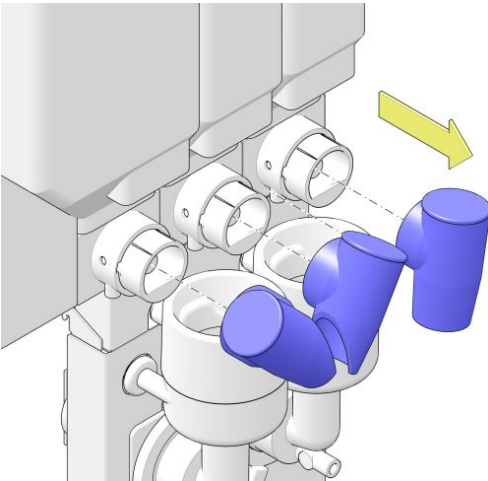

3. Turn the bayonet catches counterclockwise (approx. 10°).

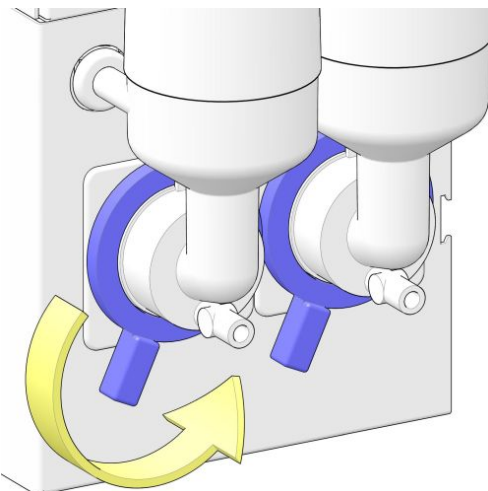

4. Pull the mixer houses in the direction of the arrow and remove them from the machine.

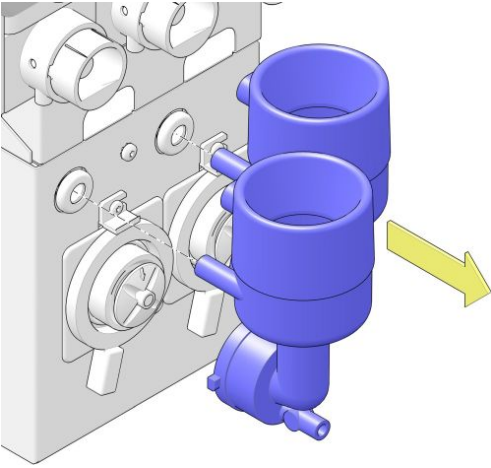

5. Pull the mixer propellers in the direction of the arrow and away from the shaft.

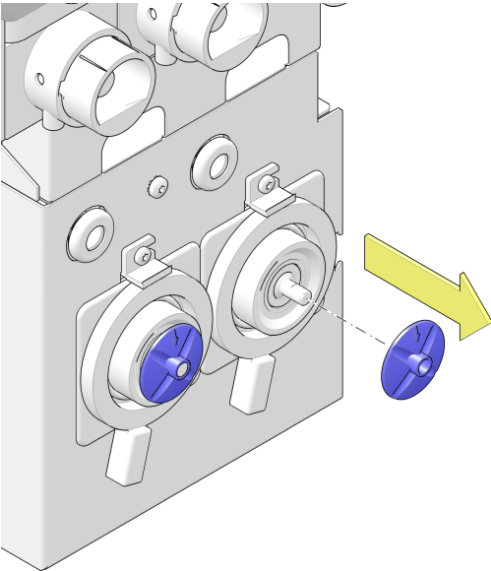

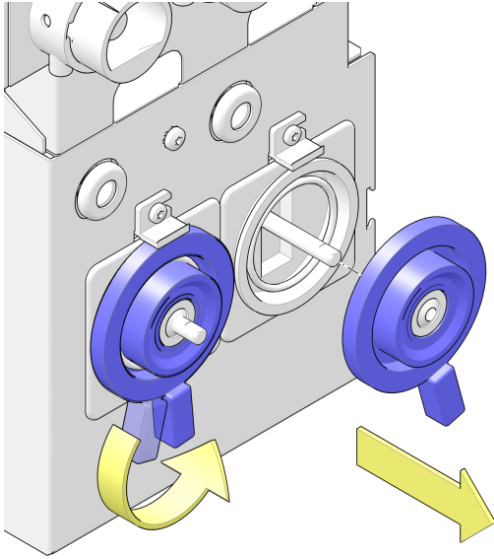

6. Turn the bayonet catches counterclockwise (approx. 10°) again to release and pull them in the direction of the arrow away from the machine.

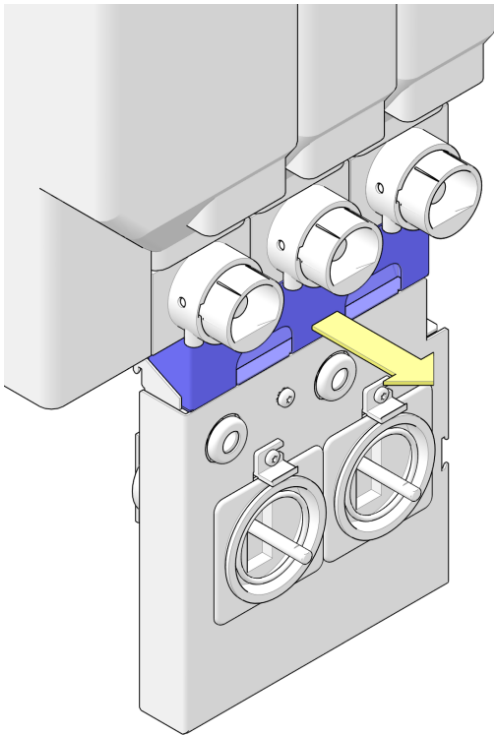

7. Pull the exhaust filter drawer in the direction of the arrow and remove it from the machine.

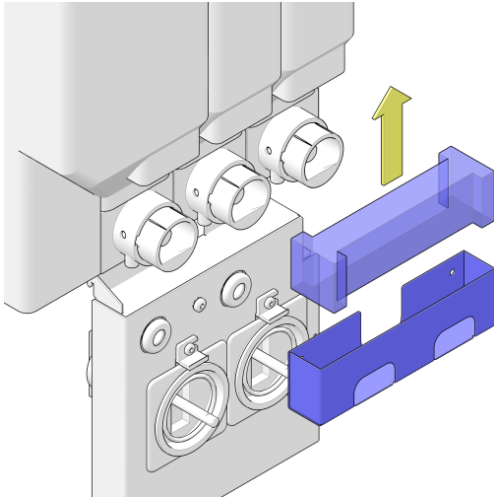

8. Remove the exhaust filter from the drawer.
9. Rinse out all removed parts of the mixing system with clean warm water.
 - Make sure to clean the inside of the hoses with a hose cleaning brush and pay attention to inside corners in the hoses.

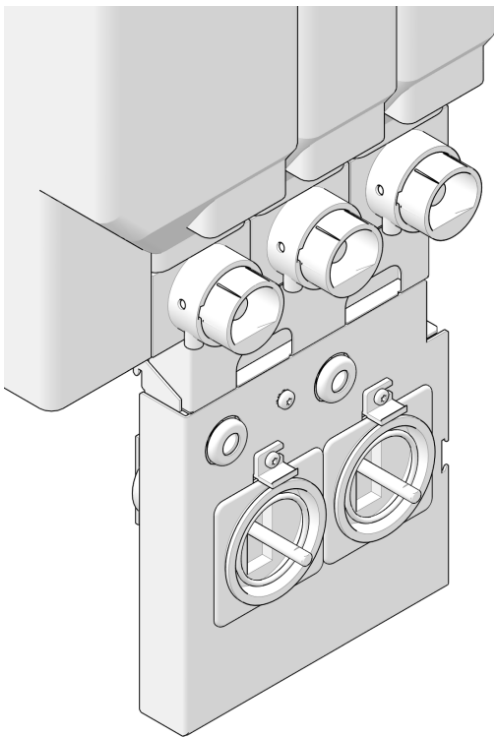

10. Clean the parts of the mixing system that remain in the machine with a brush.
11. Before continuing with the installation of the mixing system make sure **ALL** parts are dry.



TIP

When available, use the clean and dry parts from the hygiene kit. The cleaning of the removed parts can be done after the machine has been put in operation again.

12. Insert the mixer exhaust filter in the filter drawer.



CAUTION

Make sure the exhaust filter is **completely dry** before installing it in the filter drawer.

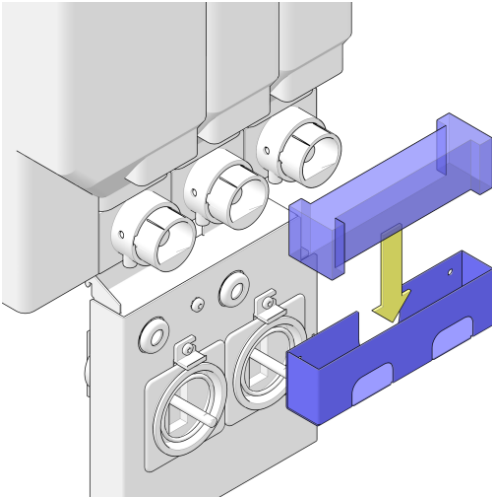

13. Install the filter drawer.

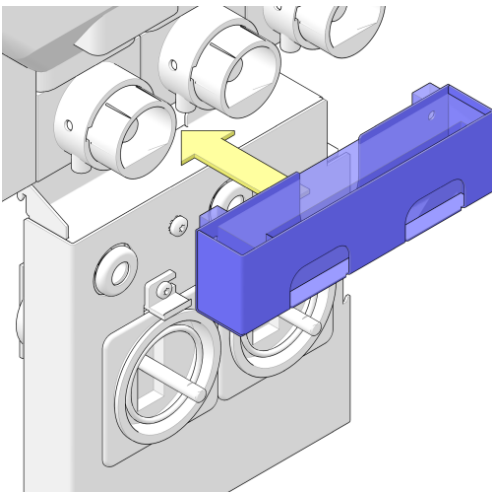

14. Install the bayonet catches and turn clockwise (approx. 10°).

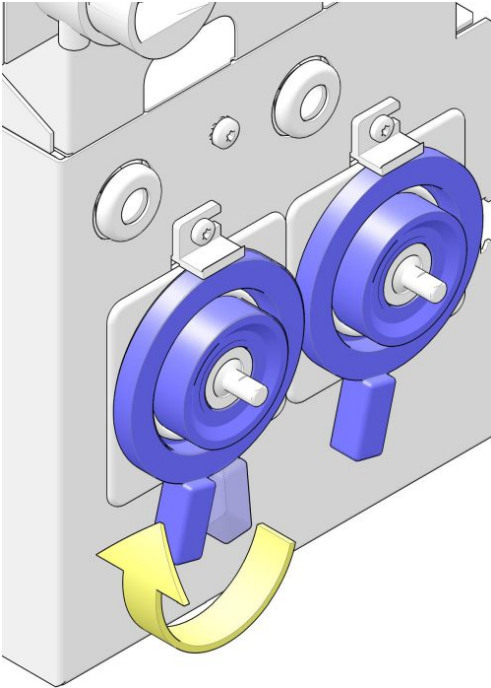

15. Install the mixer propellers.



NOTE

Make sure that the **arrow** on the mixer propeller points in the direction of the **flat** side of the shaft.

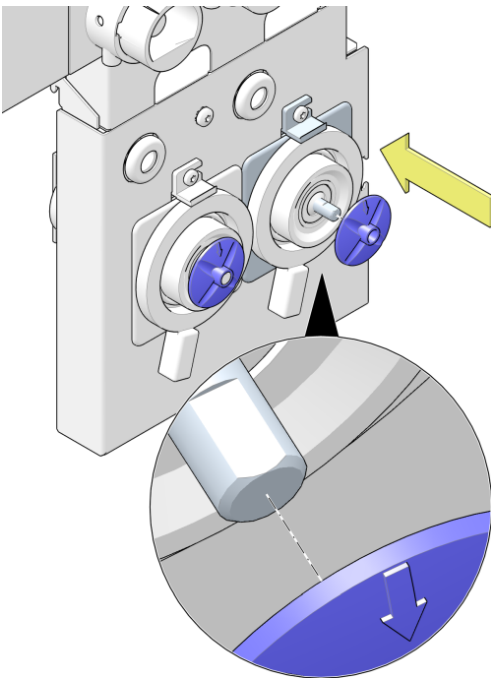

16. Install the mixer houses.

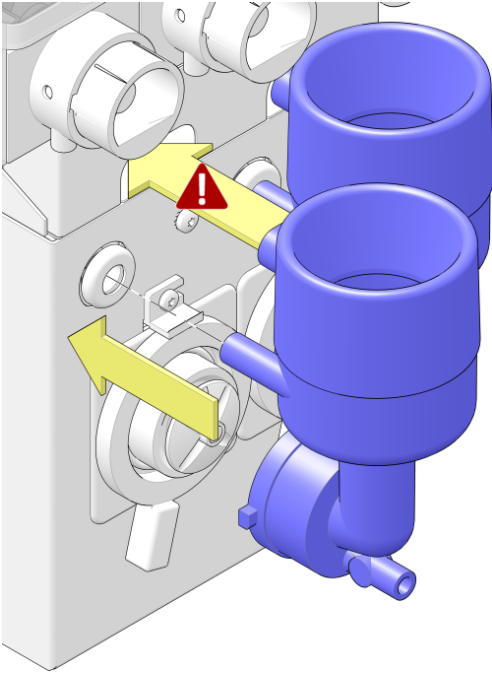

NOTE

Make sure that the mixer suction trap connects properly to the opening in the filter drawer.

17. Turn the bayonet catches clockwise to lock the mixer houses.

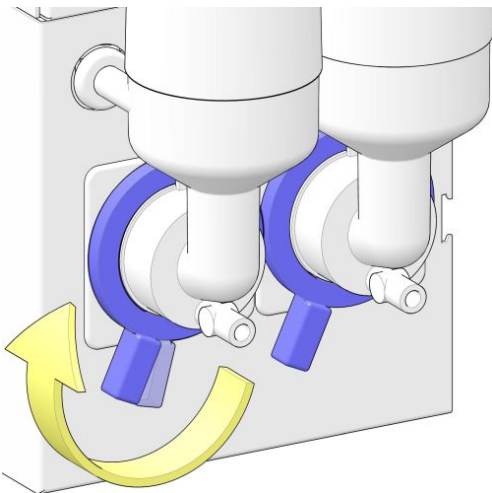

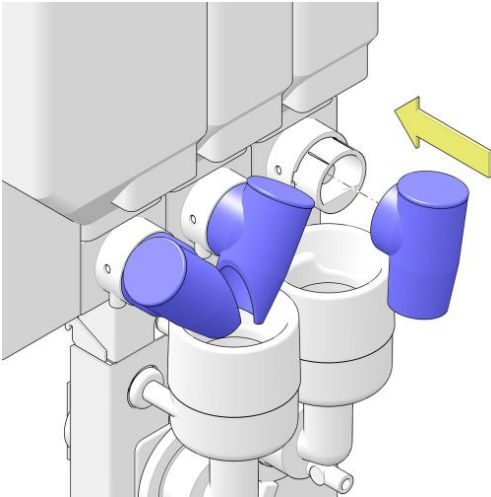

18. Install the canister outlets on the canisters and make sure the locations and positions are correct.

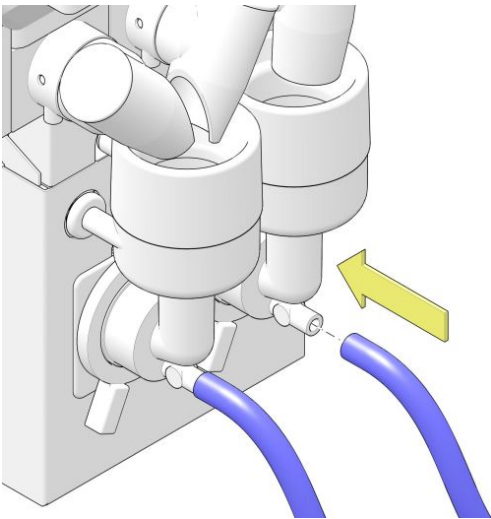

19. Connect the outlet hoses to the mixers.

5.6.13 Remove and clean the brewer

Purpose For full cleaning with water, the brewer must be removed from the coffee machine. The brewer bracket must be checked and cleaned to prevent malfunctioning of the brewer.



WARNING

Do not take the brewer itself apart. Only properly trained personnel may work on the brewer itself. Instructions for performing work on the brewer itself is found in the technical manual.

Required Use the following parts to perform the procedure:

- Pipe brush cleaner.
- Hose cleaning brush.

Interval Perform this procedure:

- At least weekly (see [Weekly maintenance](#) on page 42), increase the frequency if needed

Procedure Perform the following steps:

1. Loosen the brewer outlet from the brewer together with the connecting hose and outlet nozzle.

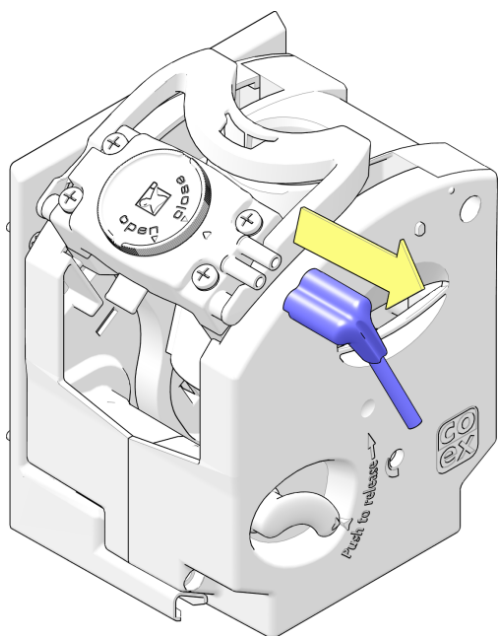

2. Locate the fixation handle on the brewer.

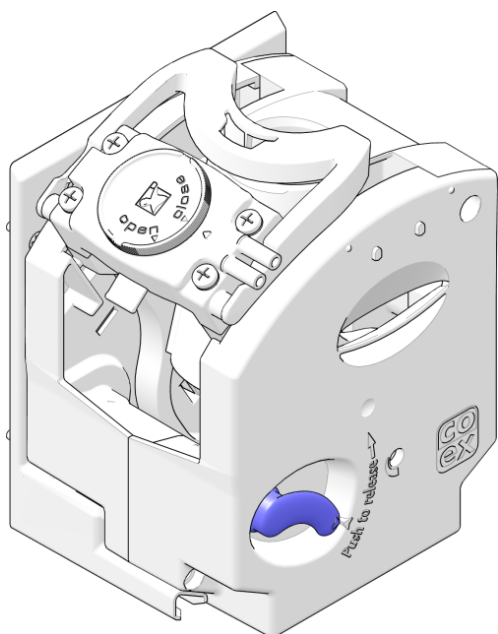

3. Push the fixation handle upwards and, while keeping the handle in the upward position, pull and lift the brewer in the direction of the arrow out of the coffee machine.

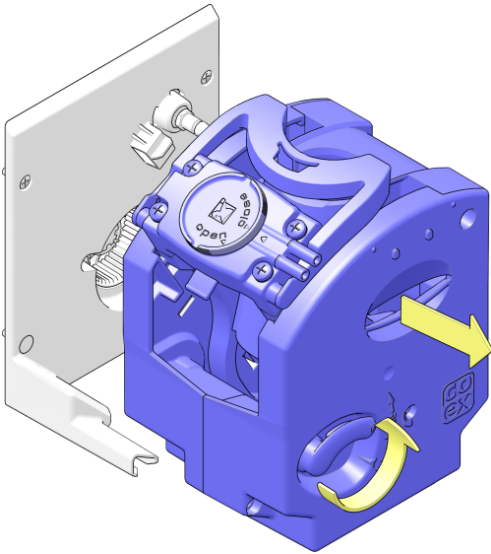

4. Make sure the brewer bracket in the coffee machine is clean; clean the water connection (A) and the motor coupling (B).
5. Rinse the brewer and the other removed parts with clean warm water.
 - Make sure to clean the inside of all hoses with the hose cleaning brush and pay extra attention to the corners inside the hoses.

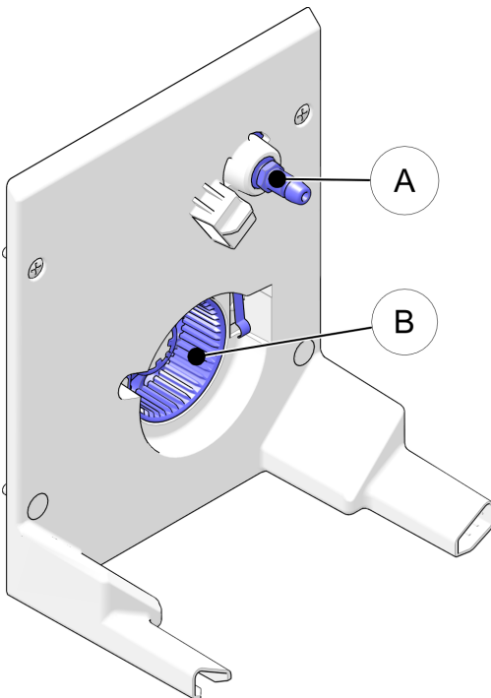

6. Remove any residue inside the brewer outlet pipes with a small pipe brush cleaner.

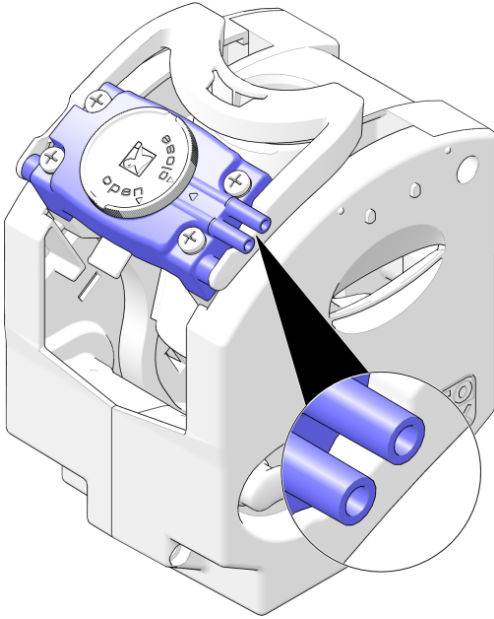

7. Place the brewer on the bracket and push the brewer firmly in the bracket until you hear a click.
 - Make sure that the fixation handle is in the down position.

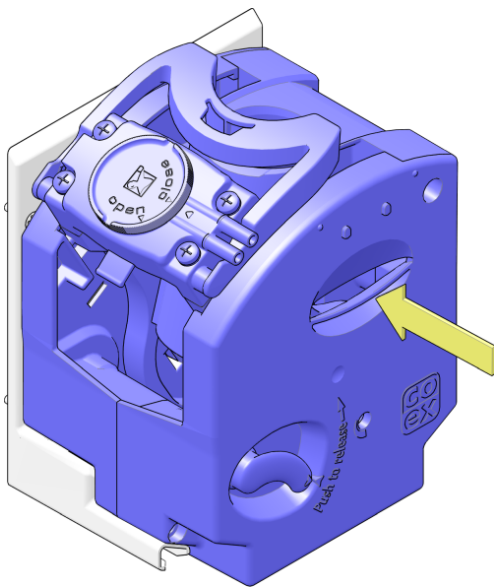

CAUTION

When the brewer is not installed correctly, the brewer can cause errors or jump out of the bracket seating during a brew cycle.

8. Install the brewer outlet with the outlet hose.
 - To prevent leaking make sure the CoEx outlet (see inset) is pushed completely on the outlet pipes of the brewer head.

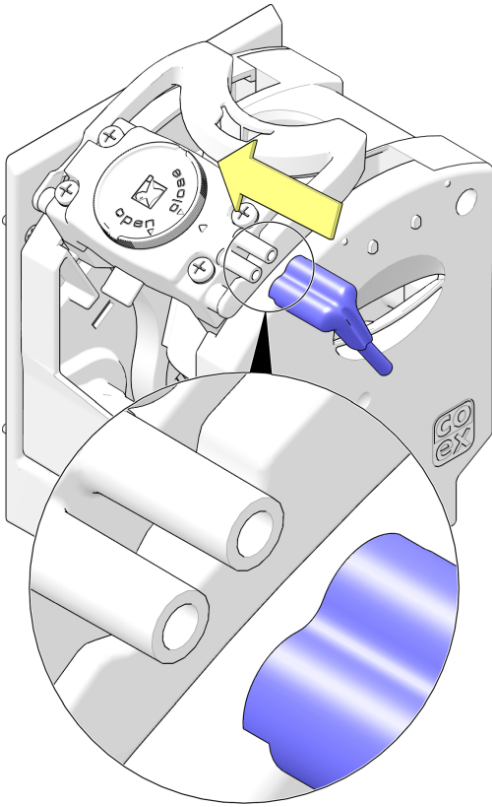

5.6.14 Clean brewer with cleaning tablet



NOTE

Failure to clean the brewer with the recommended cleaning tablet available from the manufacturer will void the warranty on related parts. Not cleaning the brewer can cause the machine to malfunction! Our advice is to do this at least once a week. If you suffer from clogged filter heads, we advise you to increase the frequency.

Purpose Cleaning of the brewer with a cleaning tablet removes all coffee residue.

Required Use the following parts to perform the procedure:

- Cleaning tablet.
- Rinsing tub or 1 liter jug.
- Protective clothing, gloves and safety glasses.
- Green service key.

Interval Perform this procedure:

- At least once a week, increase the frequency if needed.



NOTES

- Total time for the cleaning cycle is 8 minutes.
- A message is shown if the brewer is **not** cleaned after 7 days.
- A message is shown and coffee dispense is **disabled** if the brewer is not cleaned after 9 days.

Procedure Perform the following steps:

1. [Open the door](#) (on page 45).
2. In the **Service** menu, tap the **[Maintenance]** button and then the **[Brewer cleaning cycle]** button.



NOTE

Depending on model the button text can be different.

- Follow the *Cleaning Cycle* instruction shown on-screen and described in the next steps.

3. Place the cleaning tablet in the brewer.

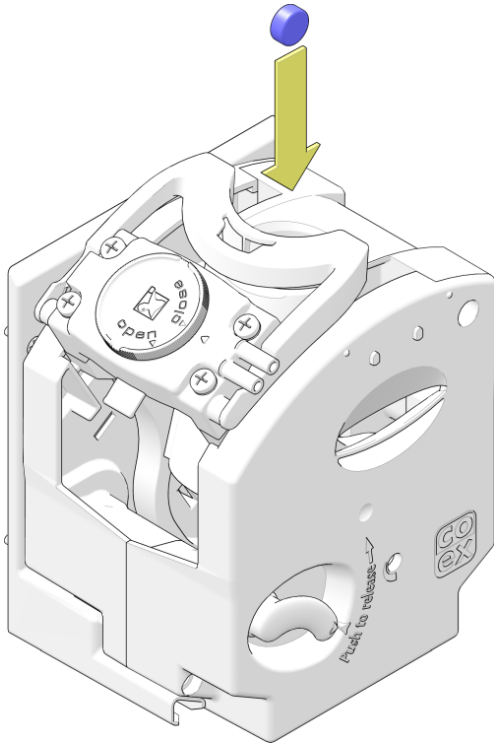

WARNING

Wear protective clothing, gloves and safety glasses when working with cleaning tablets.

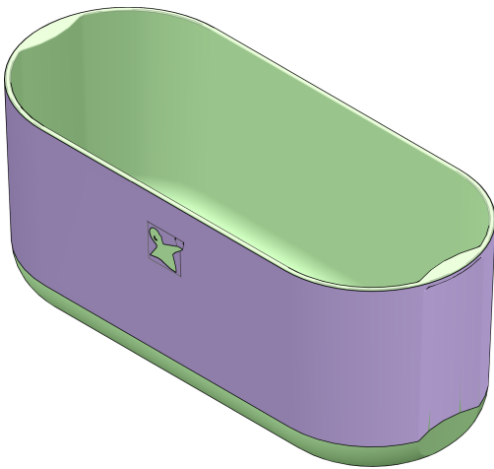

4. Place a rinsing tub under the outlet nozzle.
5. [Insert the service key](#) (on page 89) in the door.
6. In the **Service** menu, tap the button **[Start the cleaning cycle]**.
 - Wait until the cleaning cycle is **completely** finished.



WARNING

Never cancel or interrupt the cleaning cycle. Repeat the full cleaning procedure if the cleaning cycle is not completely finished.

7. [Remove the service key](#) (on page 90) from the door.
8. Remove and empty the rinsing tub.

5.6.15 Unblock the grinder

Purpose

Occasionally small twigs or small rocks (known as foreign objects) are in between the fresh beans. The grinder will stop if these objects are blocking the grinder. A message '*Grinder blocked*' (see [Message: Grinder blocked](#) on page 93) is displayed in the warning message area.

Procedure

To unblock the grinder perform the following steps:

1. Locate the grinder that needs cleaning up.

**WARNING**

To prevent possible activation of the grinder(s), keep the door open and never place the service key.

2. Remove the canister to get access to the grinder.

**NOTE**

Check the section [Fill up the bean canister](#) (on page 83) for details about the removal of the canisters. When the canister is removed the grinder itself is visible.

Grinder type

Determine the grinder type.

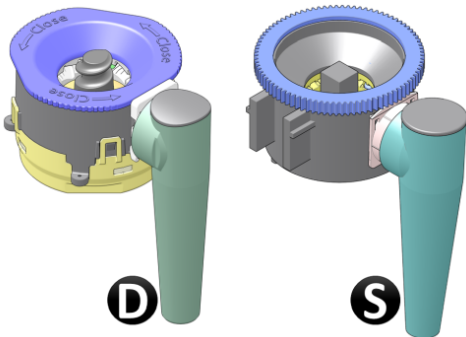

1. If the coffee machine contains a grinder, one of two grinder types are possible:

- D) the D-grinder, recognizable by the grinder top house that can be removed or
- S) the original Schaerer grinder, that contains a gear-like top.

If the machine contains a D-grinder, continue the cleaning procedure with step 5. Cleaning the Schaerer grinder is described in the next steps.

2. To clean the Schaerer grinder, lift and remove the grinder from the grinder base.

**CAUTION**

The grinder is filled with beans and ground coffee. When the grinder house is turned upside down, coffee beans and ground coffee can fall out.

3. Keep the grinder upside down. Turn the squared top inside the geared wheel at the top side, or the shaft at the bottom side, back and forth repeatedly to loosen and remove the foreign objects.

**NOTE**

The shaft should rotate easily if nothing is blocking the grinder.

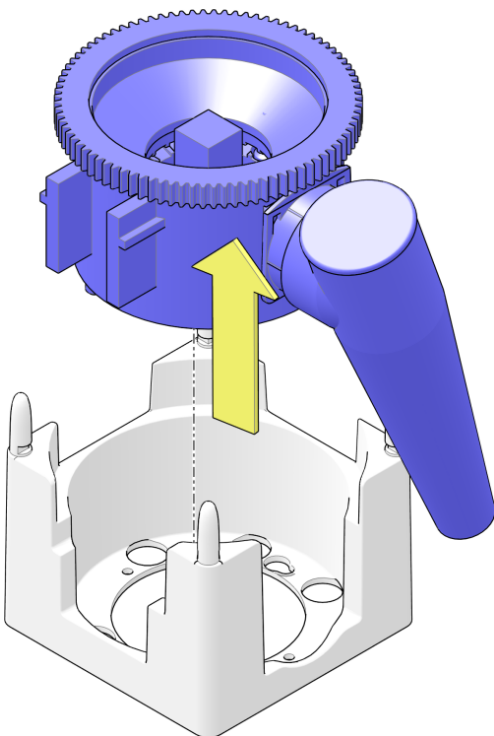

4. Place the grinder back into the grinder base and continue with step 12.



TIP

If needed, rotate the squared top a little to allow the ribbed shaft to fit the grinder motor and is fully lowered inside the grinder base.

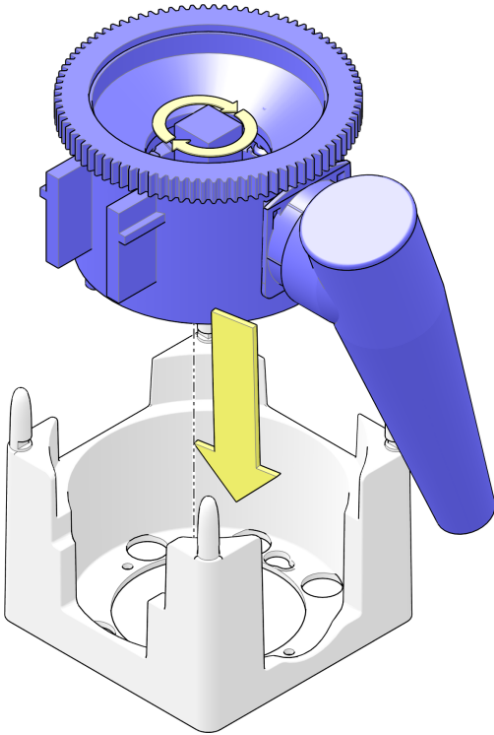

5. To clean the D-grinder, lift and remove the grinder from the base.

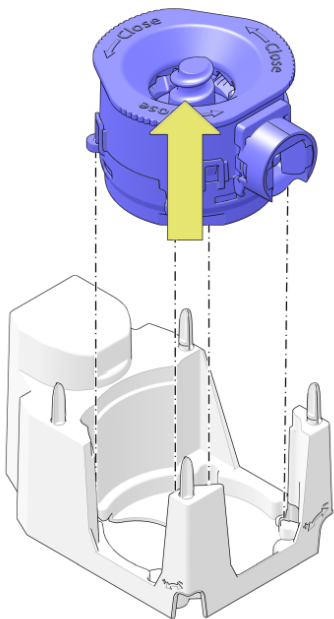

6. Pull out the clips of the grinder outlet (1), slide the outlet from the grinder house (2) and remove it from the grinder.

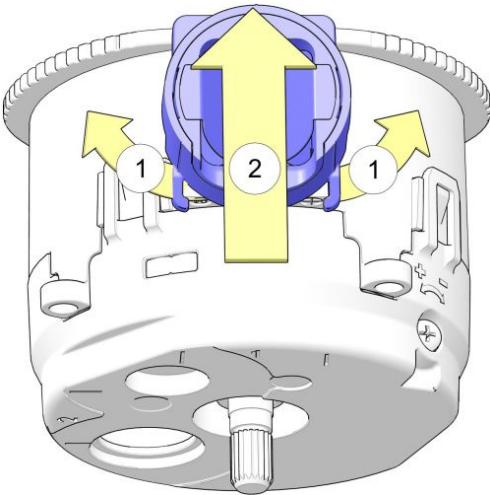

7. Loosen the bayonet locked grinder house top in the direction of the arrow and remove it from the grinder.

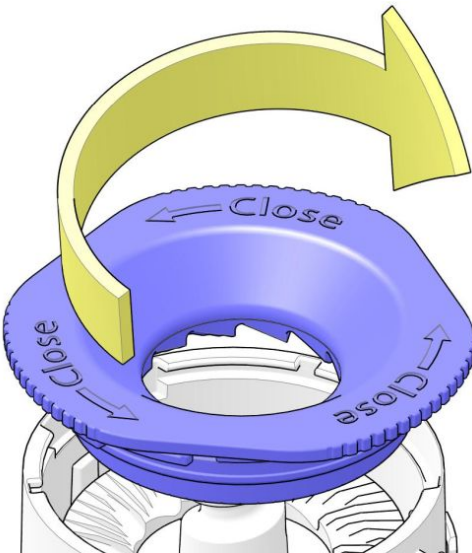

8. Clean both grinder discs and the inside of the grinder house.

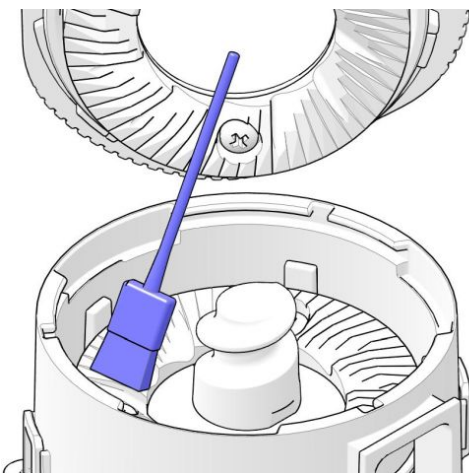

9. Place the grinder house top assembly, and turn it in the direction of the arrow to lock.

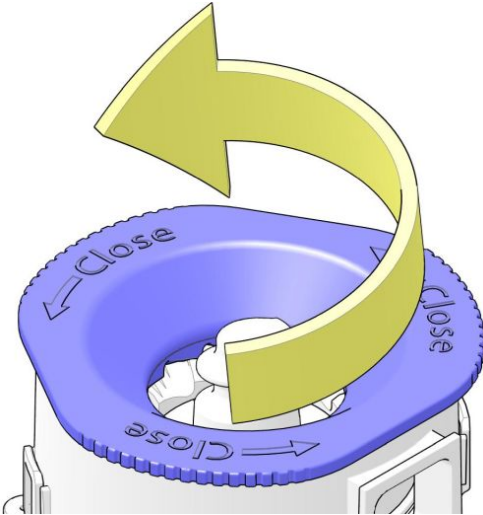

10. Slide the outlet on the grinder house in the direction of the arrow.
 - Make sure the clips lock properly.

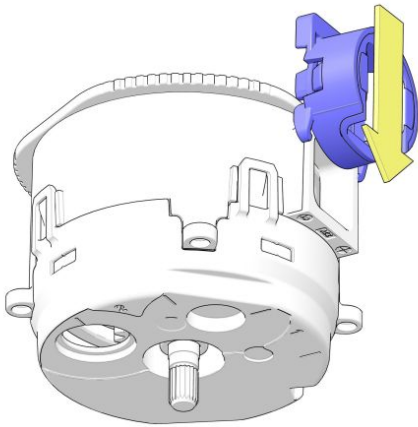

11. Place the grinder back into the grinder base.
12. Place back the canister.

i **TIP**
Check the last steps of section [Fill up the bean canister](#) (on page 83) for more details.

13. [Close the door](#) (on page 45) and lock with the key.
14. Leave the **Service menu**.

i **TIP**
Dispense two cups of coffee to fill up the grinder with fresh coffee and throw the contents of the cups away.

15. Check correct functioning by taking a test coffee.

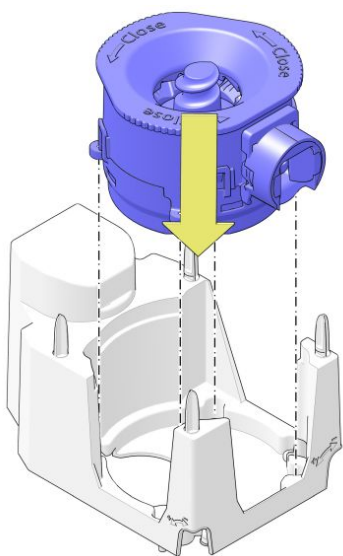

5.6.16 Fill up the cup dispenser — optional

Purpose Follow this procedure when the machine contains a cup dispenser. In order to prevent that the machine can no longer dispense drinks due to a lack of cups, the machine must be refilled in time.



TIP

It is always possible to place a cup by hand.

Required Use the following parts to perform the procedure:

- Paper or plastic cups for coffee machines (diameter 70 mm or 73 mm).

Interval Perform this procedure:

- When needed.

Procedure Perform the following steps:

1. [Open the door](#) (on page 45) of the machine.
2. On the inside of the door flip up the locking lever of the cup dispenser door.
3. Open the cup dispenser door.



NOTE

Be careful when opening the cup dispenser door. Cups can fall out.

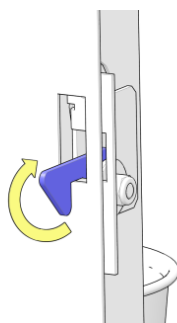

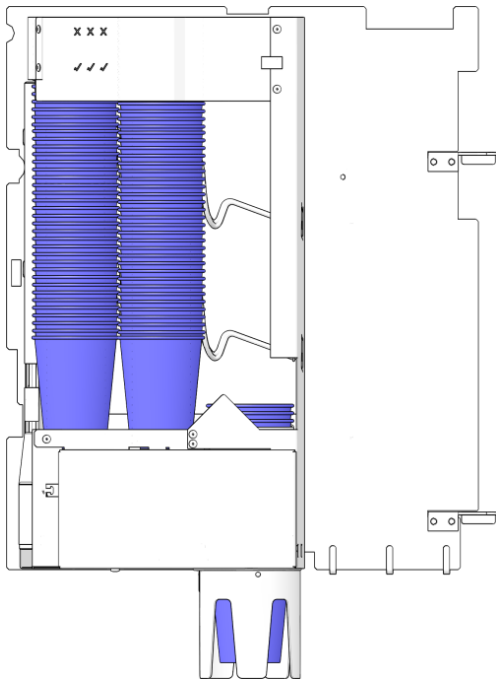

4. Place the new cups in the dispenser door.
 - A maximum of three stacks of cups is possible. Start filling with the stack on the right side.

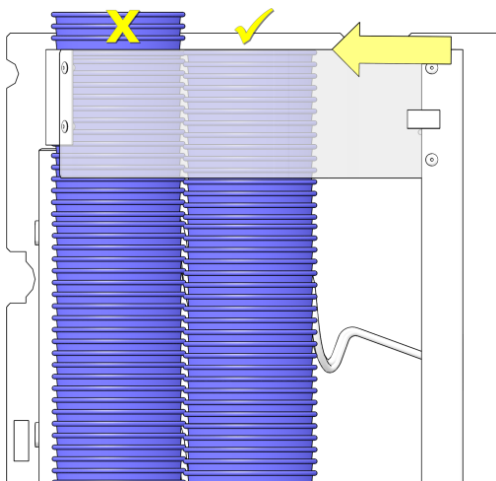

5. To prevent damage to the cups do not stack them higher than the top support plate. Remove all cups visible above the support plate.
6. Close and lock the dispenser door.

5.6.17 Clean the tea brewer

Purpose Cleaning of the tea brewer removes all residue. To clean the tea brewer, it needs to be removed from the coffee machine.

Interval Perform this procedure:

- Weekly.

Procedure Perform the following steps:

1. [Open the door](#) (on page 45).

2. Remove the brewer from the bracket.

- Push down and hold the bottom part of the bracket (A).
- Tilt the tea brewer in the direction of the arrow (B) to release it from the bottom fixation of the bracket.
- Lower the brewer (C) out of the top fold of the bracket.

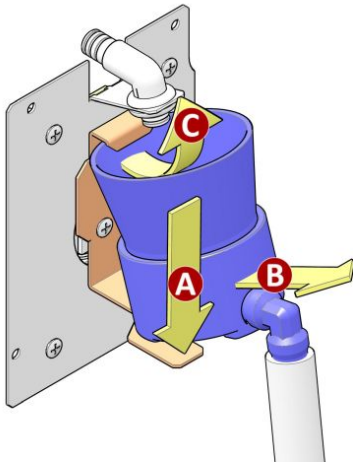

3. Remove the hose from the dispenser arm.

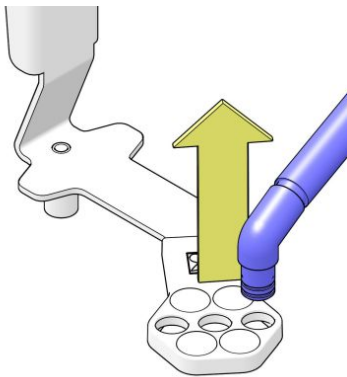

4. Disassemble the tea brewer.

5. Clean all parts, including the hose, with warm water.

6. Assemble the tea brewer.

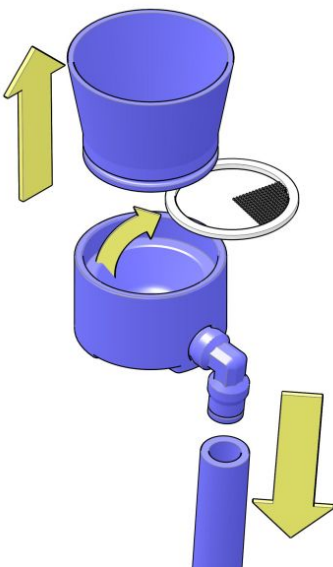

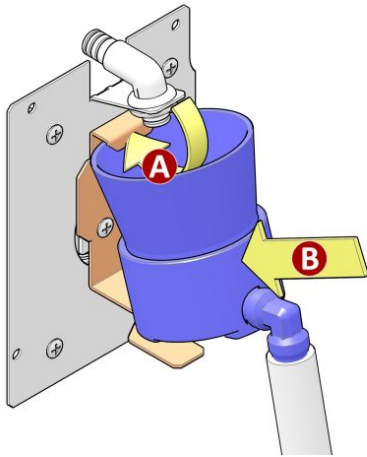

7. Install the brewer.

- Position the brewer inside the top fold of the bracket (A).
- Push the lower part of the brewer inside the bracket (B) and make sure it locks properly in position.

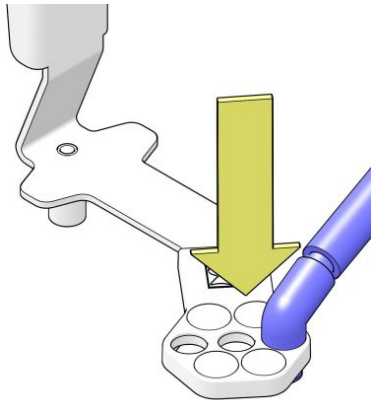

8. Insert the hose in the dispenser arm.

5.6.18 Clean the canisters

Purpose All ingredients leave residue inside the canister. To clean the canisters they need to be removed from the machine.

Interval Perform this procedure:

- Monthly (see [Monthly maintenance](#) on page 43), increase the frequency if needed

Procedure Perform the following steps:

1. [Open the door](#) (on page 45).



WARNING

To prevent possible activation of the machine, never place the service key.

2. Open the top lid (see [Open or close top lid](#) on page 46) of the coffee machine.

3. Remove the canisters from the machine.
 - Check the first steps in the section [Fill up the ingredient canisters](#) (on page 80) for more details about the removal of the canisters.
4. Unlock (optional) and remove the lid from the canisters.
5. Empty the canisters.
6. Clean the canisters with warm water.

**NOTE**

Use a mild detergent if warm water only is not sufficient.

7. Dry the canisters thoroughly on the inside and outside.

**WARNING**

Do not fill the canisters until they are completely dry. The product may form lumps which makes the system unusable.

5.6.19 Clean the cold water outlet nozzle — optional

Purpose The cold water outlet nozzle must be cleaned regularly to prevent bacteria growth.

Required Use the following parts to perform the procedure:

- Multi purpose, disposable cloth.
- Cleaning agent.
- Disposable paper towels.
- Rinsing tub or 1 liter jug.
- Protective clothing, gloves and safety glasses.

**NOTE**

Do not use aggressive cleaning products or abrasives to clean (parts of) the machine.

Interval Perform this procedure:

- Weekly (see [Weekly maintenance](#) on page 42), increase the frequency if needed (depending on machine usage and environmental conditions)

Procedure Perform the following steps:

**WARNING**

Wear protective clothing, gloves and safety glasses when working with cleaning chemicals.

1. Use the cloth to apply the cleaning agent. Submerge a clean cloth into the cleaning agent (concentration recommended by cleaning agent manufacturer's instructions). Remove the cloth and remove excess water.
2. Clean the cold water outlet nozzle wiping the cloth over the entire area re-submerging the cloth as necessary.
3. Rinse the cloth in clean warm water and wipe off excess cleaning agent residue and soil.
4. Dry cold water nozzle using disposable paper towels.
5. [Close the door](#) (on page 45) of the coffee machine.
6. Place a rinse tub below the cold water outlet nozzle.
7. Leave the **Service menu**: Tap the **[Exit]** button and then the **[Close door and press here to quit service]** button to leave the **Service menu**.
8. Select a full jug of cold water and dispense at least 1 liter of cold water and ensure any cleaning residue is flushed out.

5.6.20 Deep clean the cold water outlet nozzle — optional

Purpose The cold water outlet nozzle must be cleaned and disinfected regularly to prevent bacteria growth.

Required Use the following parts to perform the procedure:

- Multi purpose, disposable cloth.
- Cleaning agent.
- Protective clothing, gloves and safety glasses.
- Disinfectant solution.
- Disposable paper towels.
- Rinsing tub or 1 liter jug.
- Brush.



NOTE

Do not use aggressive cleaning products or abrasives to clean (parts of) the machine.

Interval Perform this procedure:

- Monthly (see [Monthly maintenance](#) on page 43), increase the frequency if needed (depending on machine usage and environmental conditions)

Procedure Perform the following steps:



WARNING

Wear protective clothing, gloves and safety glasses when working with cleaning chemicals.

1. Submerge a clean cloth in warm water. Pre clean the cold water outlet nozzle using the cloth.
2. Submerge a clean cloth into the cleaning agent (concentration recommended by cleaning agent manufacturer's instructions). Remove the cloth and remove excess water.
3. Clean the cold water outlet nozzle wiping the cloth over the entire area re-submerging the cloth as necessary.
4. Using a brush, brush around the cold water nozzle to dislodge any dried on soil. Remove the soil with a cloth.
5. Soak a clean disposable cloth in clean warm water and rinse the outlet nozzle until all soil and cleaning agent residues are removed.
6. Soak a clean disposable cloth in disinfectant solution, ensure that the whole area is wiped.
7. Leave for 10 minutes.
8. Rinse off disinfectant using disposable cloth in clean warm water.
9. Dry cold water nozzle with disposable paper towels.
10. [Close the door](#) (on page 45) of the coffee machine.
11. Place a rinse tub below the cold water outlet nozzle.
12. Leave the **Service menu**: Tap the **[Exit]** button and then the **[Close door and press here to quit service]** button to leave the **Service menu**.
13. Select a full jug of cold water and dispense at least 1 liter of cold water and ensure any cleaning residue is flushed out.

5.6.21 Fill up the ingredient canisters



NOTE

- Make sure that the canisters remain filled with a layer of at least 1.6 in of product.
- Only use ingredients recommended by the supplier of the machine.

- To fill up a bean canister (optional) check the section Fill the bean canister.

Purpose To prevent that the machine can no longer dispense drinks due to a lack of ingredients, the machine must be refilled in time.

Required Use the following to perform the procedure:

- Ingredients.

Procedure Perform the following steps:

1. [Open the door](#) (on page 45).

**WARNING**

To prevent possible activation of the machine, never place the service key.

2. Open the top lid (see [Open or close top lid](#) on page 46) of the coffee machine.

**NOTE**

Filling the canisters must be done outside the machine.

3. Remember (or write down) the position of the outlets and turn the outlets of the canisters upwards.

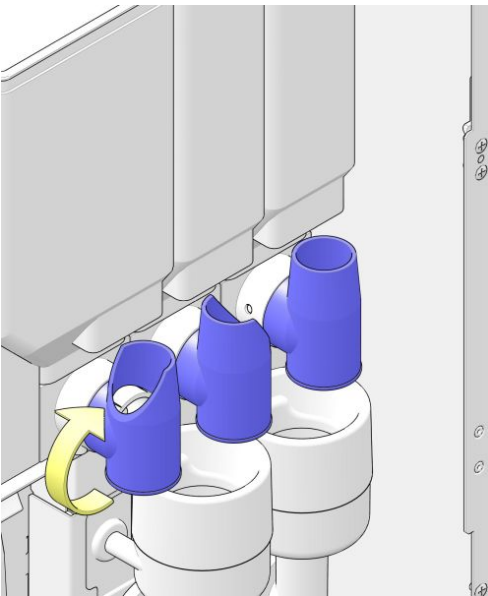

4. Slightly lift the canister at the front until the small locking ridge (see inset) is visible.
5. Pull the canister towards you and take it out of the machine.

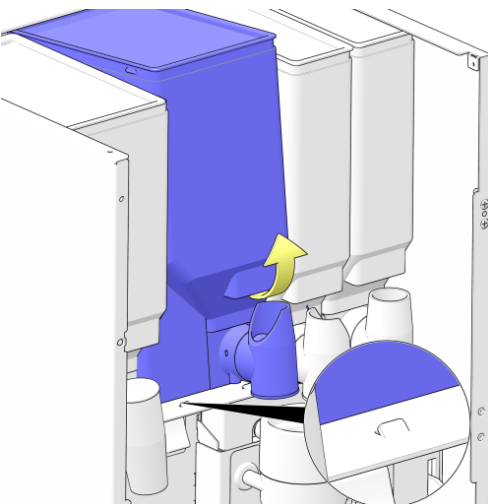

6. Remove the lid and place the canister on a stable surface.
7. Fill the canister with the ingredient indicated on the canister.

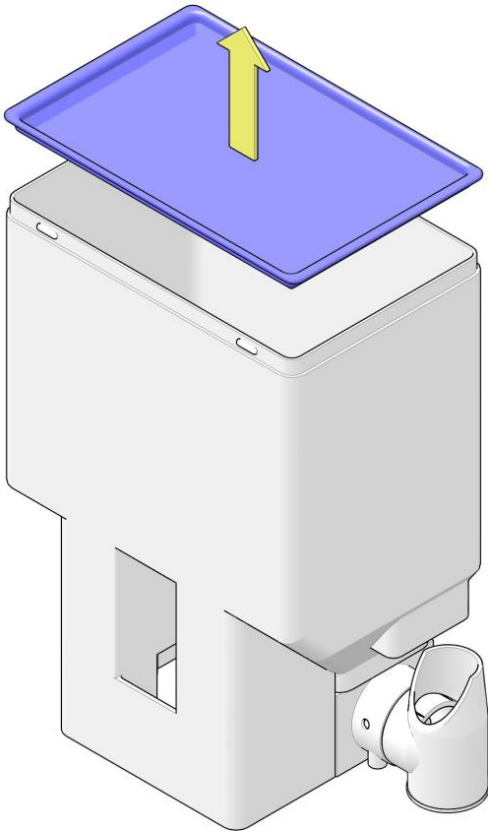

TIP

Do not fill the canisters more than necessary for one or two days. This will keep the products fresh.

8. Place the lid back on the canister and position the canister back into the machine.

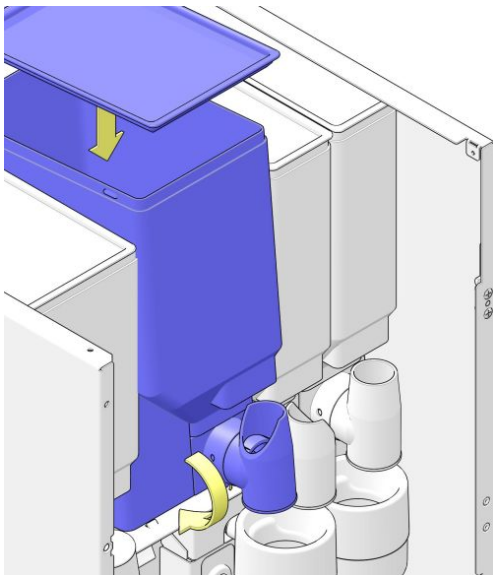

CAUTION

Make sure the drive at the back of the canister fits well on the motor drive.

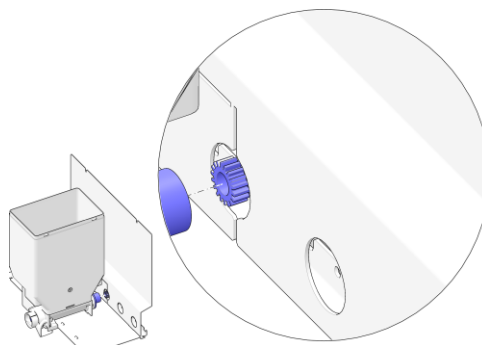

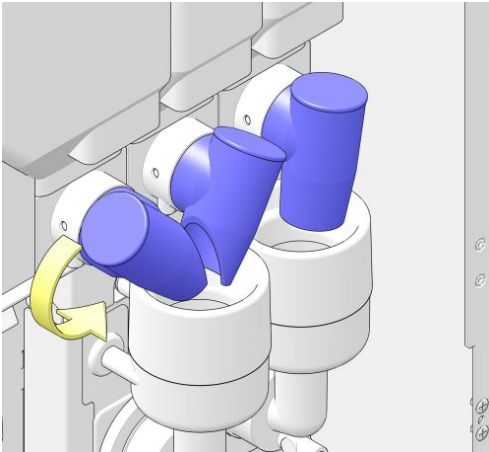

9. Turn the outlets of the canister downwards.



CAUTION

Check the position of the outlet of the canister. It must be positioned towards the correct mixing bowl.

10. Close the top lid (see [Open or close top lid](#) on page 46) of the machine.

5.6.22 Fill up the bean canister



NOTE

- Make sure that the canisters remain filled with a layer of at least 1.6 in of product.
- Only use ingredients recommended by the supplier of the machine.

- To fill up an ingredient canister (optional) check the section [Fill up the ingredient canisters](#) (on page 80).

Purpose

In order to prevent that the machine can no longer dispense drinks due to a lack of ingredients, the machine must be refilled in time.

Required

Use the following to perform the procedure:

- Coffee beans.

Procedure

Perform the following steps:

1. [Open the door](#) (on page 45).



WARNING

To prevent possible activation of the grinder(s), never place the service key.

2. Open the top lid (see [Open or close top lid](#) on page 46) of the coffee machine.



NOTE

Filling the canisters must be done outside the machine.

3. Locate the canister locking slider in between the grinder and the bean canister.

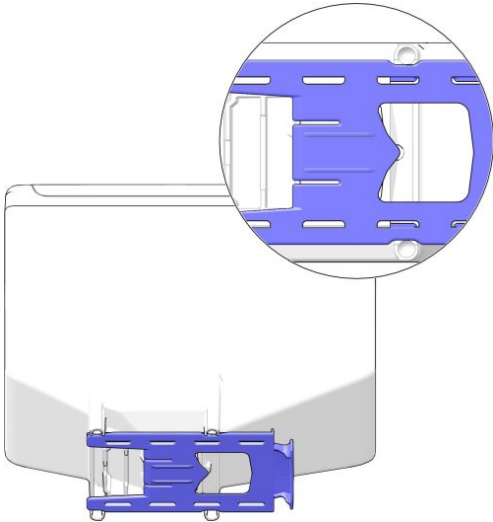

4. Pull the canister locking slider in the direction of the arrow. The bean canister will be closed and unlocked from the grinder base.
5. Lift the bean canister from the grinder base and take it out of the machine.

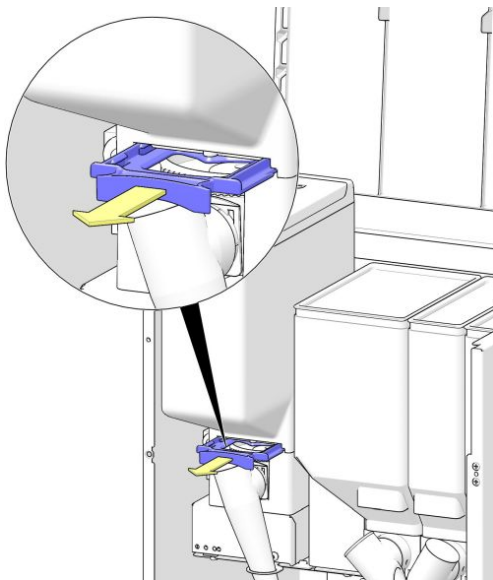

CAUTION

When the canister locking slider is not fully pulled out, coffee beans will fall out of the canister.

6. Place the bean canister on a stable and flat surface for refilling.

7. Unlock the lid (optional). Lift the lid in the front and then pull the lid from the canister in the direction of the arrow.
8. Fill the canister with fresh coffee beans.



TIP

Fill the canister with beans sufficient for one or two days. This will keep the products fresh.

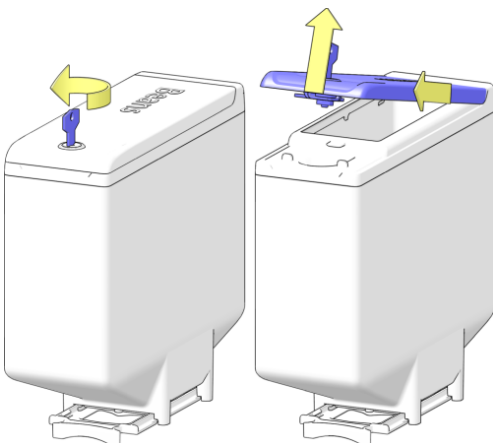

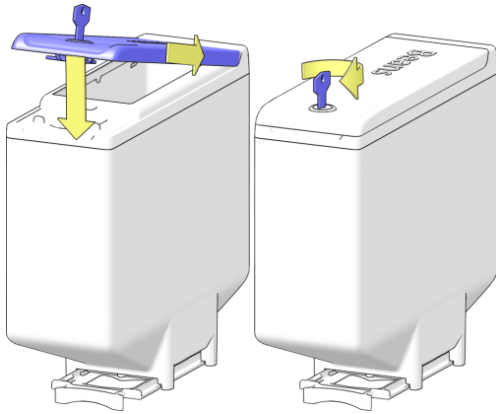

9. Place the back side of the lid on the canister and then lower the front side. Lock the lid (optional).

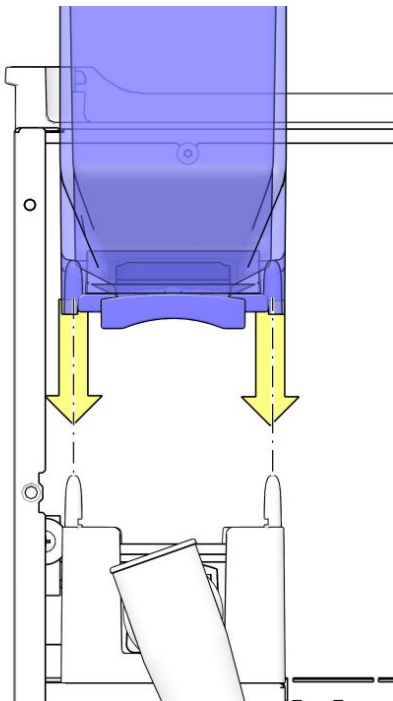

10. Place the bean canister back into the coffee machine on the four position ridges of the grinder base.

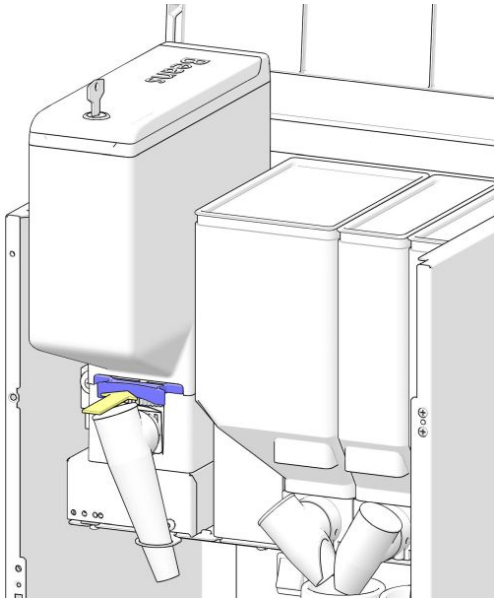

11. Push the canister locking slider back in the direction of the arrow to open the bean canister and secure it to the grinder base.
12. Repeat the procedure if more bean canisters must be filled up.

5.6.23 Enter canister ingredient levels — optional

Purpose When activated the coffee machine displays a message on the screen when the ingredient canisters are almost empty. Based on the number of beverages taken, the machine calculates the amount of ingredients left in the canisters. When the canisters are filled up the counters must be reset. Follow the steps in the procedure below to reset the counters.

Interval Perform this procedure:

- When this option is active the *Enter ingredient level screen* is displayed when the **[Exit]** button is tapped in the **Service** menu to return to the **Main** menu (see [Main menu - Cup dispensing](#) on page 20).

Procedure Perform the following steps:

1. When the **[Exit]** button is tapped to leave the **Service** menu the *Enter ingredients levels screen* is displayed.
 - The current filling level of each canister is displayed (only the canisters activated for this option are shown).
2. To change a canister filling level tap one of the **ingredient** buttons in the left column.
 - or tap the **[Exit]** button to leave the **Service** menu.

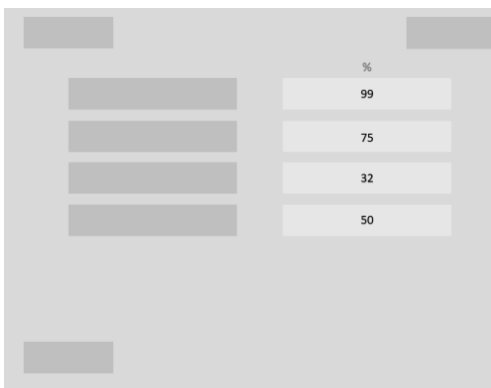

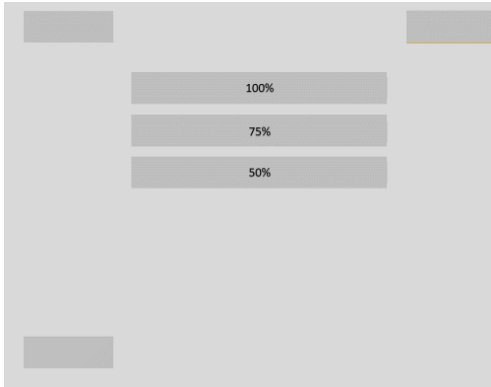

3. Tap the correct **[filling level %]** button for the selected canister.



NOTE

A completely filled canister is filled 100 %. To keep ingredients fresh it is also possible to fill the canister for 50%.

4. Repeat the steps for each canister that is filled up (or where the shown value is not correct) or tap **[Exit]** to leave the **Service** menu.

5.6.24 Clean the outside of the machine

Purpose To clean all outside areas of the coffee machine that are not cleaned in any other procedure.

Required Use the following parts to perform the procedure:

- Soft damp cloth.

Interval Perform this procedure:

- Daily (see [Daily maintenance](#) on page 42)

Procedure Clean the outside of the machine with a soft damp cloth.



NOTE

Do not use aggressive cleaning products or abrasives to clean (parts of) the machine.

5.6.25 Clean the touchscreen — optional

Purpose The touchscreen is the main interface between user and coffee machine. To ensure a hygienic and flawless use, the touchscreen must be cleaned regularly.

Required Use the following parts to perform the procedure:

- A clean soft cloth for disinfection purposes.
- (Isopropyl) alcohol.

Interval Perform this procedure:

- At least daily (see [Daily maintenance](#) on page 42).
- When announced on screen.

Procedure Perform the following steps:

1. Tap one of the buttons with the message [**PRESS here to start cleaning**]. The screen will be switched off now.
 - or tap [**Cancel**] to return to the **Main menu**.



TIP

If the Clean Screen window is not shown, tap the on-screen clock first. If no clock is displayed, check the section [Main menu - Cup dispensing](#) (on page 20) and tap on the location of the clock.

2. Clean the touchscreen with some (Isopropyl) alcohol on a clean soft cloth.



CAUTION

- Do not use any other (aggressive) chemicals to clean the surface of the touchscreen.
- Prevent dripping, do not use too much cleaning liquid on the cloth.

3. After some time, the touchscreen is switched on again. The machine returns to the **Main menu** and is ready for use.

5.6.26 The service key

Purpose For safety reasons all dispense functions are disabled if the door of the machine is opened. Use the green service key to override this safety for maintenance procedures that need a fully functioning machine.

5.6.26.1 Insert the service key

Required Use the following parts to perform the procedure:

- Green service key.

Procedure Perform the following steps:

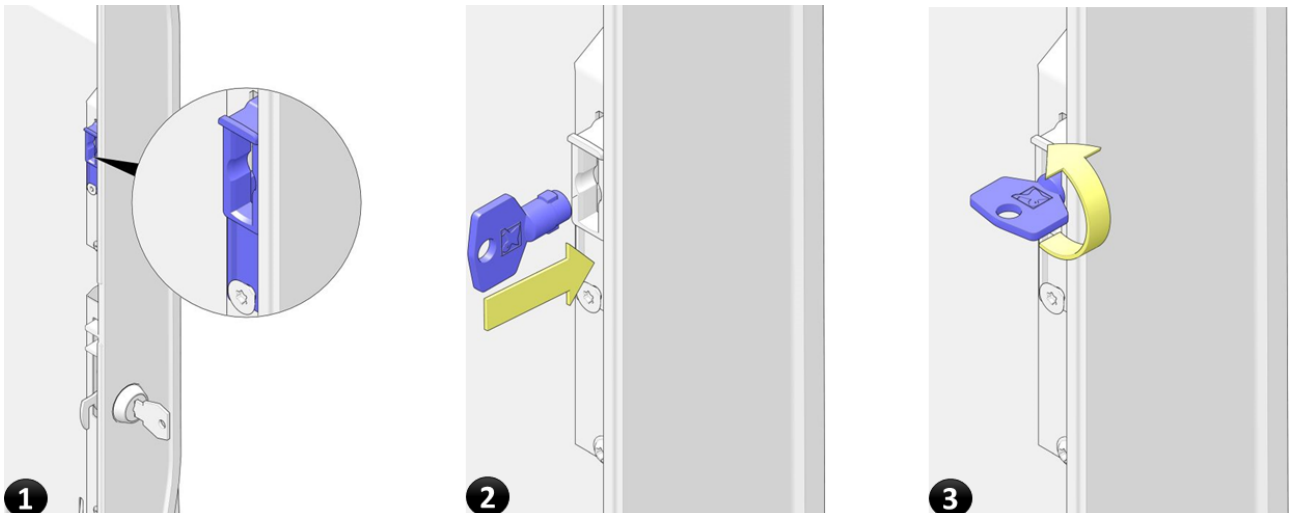

1. Locate the entry for the **Service key** on the inside of the door.
2. Insert the **Service key** in the service key entry.
3. Turn the **Service key** a quarter turn (90°).
 - The grey options in the **Service menu** change to *yellow/green*.
 - The coffee machine is now fully functional with an open door.
 - The key remains locked in the entry.



WARNING

When the service key is inserted, the machine is powered up with open door. Parts in the machine can move and hot water can flow out. Only insert the service key when requested.

5.6.26.2 Remove the service key

Required Use the following parts to perform the procedure:

- Green service key.

Procedure Perform the following steps:

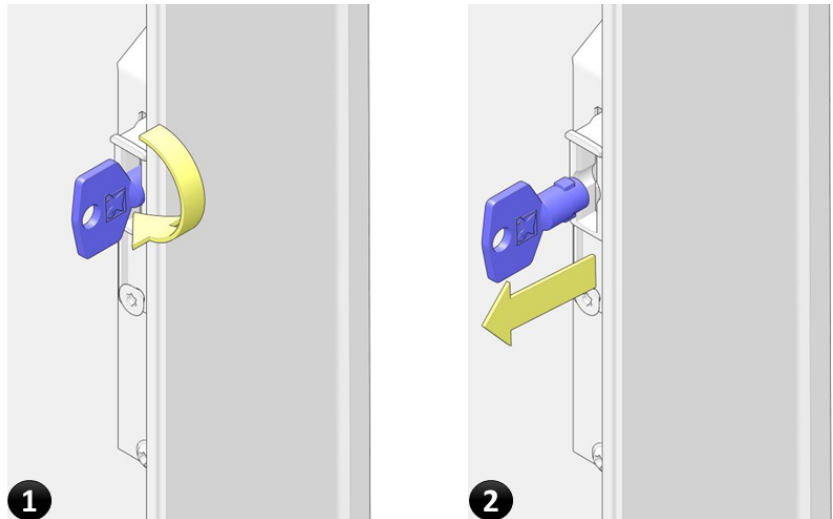

1. Turn the **Service key** a quarter turn (90°).
2. Remove the **Service key** from the door.

Troubleshooting

6.1 Messages

Always check if a message is shown on the display. If no message is shown and the machine does not work correctly, you still may find the possible cause and solution in the following table. For failures not mentioned in this manual: Consult the service engineer (see [Service and support](#) on page 3).

6.1.1 Message: Brewer not in home position

Message *Brewer not in home position*

Solution Remove and install the brewer (see [Remove and clean the brewer](#) on page 63).

If the problem persists: Consult the service engineer (see [Service and support](#) on page 3).

6.1.2 Message: Brewer out of position

Message *Brewer out of position*

Solution Remove and install the brewer (see [Remove and clean the brewer](#) on page 63).

If the problem persists: Consult the service engineer (see [Service and support](#) on page 3).

6.1.3 Message: Clean screen

Message *Clean Screen*

Cause After a defined number of consumptions, the touchscreen needs to be cleaned.

Solution Perform the steps as explained in the section [Clean the touchscreen — optional](#) (on page 87).

6.1.4 Message: Cleaning Error

Message *Cleaning Error*

Cause The cleaning cycle did not finish correctly or was interrupted.

Solution Run the cleaning cycle (see [Clean brewer with cleaning tablet](#) on page 68) again.

If the problem persists: Consult the service engineer (see [Service and support](#) on page 3).

6.1.5 Message: Communication error

Message *Communication error*

Solution Consult the service engineer (see [Service and support](#) on page 3).

6.1.6 Message: Door open

Message *Door open*

Solution [Close the door](#) (on page 45) or [insert the service key](#) (on page 89) to activate the machine.

6.1.7 Message: Drip tray full

Message *Drip tray full*

Solution Perform the following steps to solve the problem:

1. [Clean the drip tray](#) (on page 54) in front of the machine and/or clean the drip bucket (see [Clean waste bucket](#) on page 48) inside the waste bucket.
2. Make sure the water level sensors in the drip bucket / drip tray are dry.

Also see section [Daily maintenance](#) (on page 42).

6.1.8 Message: Empty waste bucket

Message *Empty waste bucket*

Solution Check the message 'Waste bucket full / Empty waste bucket' (see [Message: Waste bucket full / Empty waste bucket](#) on page 98) for more details.

6.1.9 Message: Enough water?

Message *Enough water?*

Solution Perform the following steps to solve the problem:

1. Connect and open the water supply and restart the machine.
2. [Clean brewer with cleaning tablet](#) (on page 68).
3. Check if the problem also occurs when a hot water dispense is made.

If the problem persists: Consult the service engineer (see [Service and support](#) on page 3). Do not forget to mention the results.

6.1.10 Message: Filling boiler

Message *Filling boiler*

Solution Wait until the boiler is filled.

If the message is still shown after 10 minutes: Consult the service engineer (see [Service and support](#) on page 3).

6.1.11 Message: Grinder blocked

Message *Grinder blocked*

Solution Clean the grinder (see [Unblock the grinder](#) on page 69).

6.1.12 Message: Heating boiler

Message *Heating boiler*

Solution Wait until the boiler is heated.

If the message is still shown after 10 minutes: Consult the service engineer (see [Service and support](#) on page 3).

6.1.13 Message: Install drip tray

Message *Install drip tray*

Solution Install the drip tray (see [Clean the drip tray](#) on page 54).
Also see section [Daily maintenance](#) (on page 42).

6.1.14 Message: Install waste bucket

Message *Install waste bucket*

Solution Install the waste bucket (see [Clean waste bucket](#) on page 48).
Also see section [Daily maintenance](#) (on page 42).

6.1.15 Message: Insert coins

Message *Insert coins*

Solution Perform a full payment with coins, tokens or card.
Also see section [Payment](#) (on page 39).

6.1.16 Message: Mixer blocked

Message *Mixer blocked*

Solution [Clean the mixing system](#) (on page 55).

6.1.17 Message: Machine Blocked

Message *Machine Blocked*

Cause The coffee machine is locked during this time by the scheduler and not available for use.

Solution Consult the service engineer (see [Service and support](#) on page 3).

6.1.18 Message: Machine is temporarily out of order

Message *Machine is temporarily out of order*

Cause The message is set on purpose by the operator, for instance, because there are no ingredients available. The coffee machine can not be used.

Solution As soon as the issue is solved, the operator removes the message and the machine will be available again.

6.1.19 Message: Not all ingredients available

Message *Not all ingredients available*

Solution One or more canisters must be refilled. See section [Fill up the ingredient canisters](#) (on page 80).

6.1.20 Message: No coffee detected in brewer

Message *No coffee detected in brewer*

Solution Perform the following steps to solve the problem:

1. Check if a canister must be refilled. See section [Fill up the ingredient canisters](#) (on page 80).
2. Check if the grinder runs to fill the brewer.

6.1.21 Message: No water connected / No water in boiler

Message *No water connected / No water in boiler*

Cause No water detected for more than 2 minutes.

Solution Perform the following steps to solve the problem:

1. First check if the water supply is opened / connected.
2. [Open the door](#) (on page 45) of the coffee machine to display the **Service menu**, wait 2 seconds and [close the door](#) (on page 45) to allow the coffee machine to re-activate itself.
 - If this does not help, restart the coffee machine (switch off the coffee machine (see [Switch off / Putting out of order](#) on page 46), wait 5 seconds and then switch on the coffee machine (see [Switch on](#) on page 45)).

If the problem persists: Consult the service engineer (see [Service and support](#) on page 3).

6.1.22 Message: Place cup in center

Message *Place cup in center*

Cause The cup needs to be placed under the correct dispensing nozzle before the **[Start]** button is available.

Solution If the cup is placed in the correct position, clean the cup sensor.

6.1.23 Message: Place cup right

Message *Place cup right*

Cause Cup needs to be placed under the water dispensing nozzle before the **[Start]** button is available.

Solution Perform the following steps to solve the problem:
1. If cup is placed in the correct position clean the cup sensor.

6.1.24 Message: Please load configuration

Message *Please load configuration*

Solution Consult the service engineer (see [Service and support](#) on page 3).

6.1.25 Message: Please load the User Interface

Message *Please load the User Interface*

Solution Consult the service engineer (see [Service and support](#) on page 3).

6.1.26 Message: Replace water filter

Message *Replace water filter*

Solution Consult the service engineer (see [Service and support](#) on page 3).

6.1.27 Message: Rinse brewer with tablet

Message *Rinse brewer with tablet*

Solution [Clean brewer with cleaning tablet](#) (on page 68).

Also see [Weekly maintenance](#) (on page 42).

6.1.28 Message: Startup problem

Message

Startup problem

Solution

Perform the following steps to solve the problem:

1. Open/connect the water supply.
2. Restart the coffee machine (switch off the coffee machine (see [Switch off / Putting out of order](#) on page 46), wait 5 seconds and then switch on the coffee machine (see [Switch on](#) on page 45)).

If the problem persists: Consult the service engineer (see [Service and support](#) on page 3).

6.1.29 Message: Temp. sensor disconnected

Message

Temp. sensor disconnected

Solution

Consult the service engineer (see [Service and support](#) on page 3).

6.1.30 Message: Temperature boiler (too) high

Message

Temperature boiler (too) high

Solution

Perform the following steps to solve the problem:

1. [Open the door](#) (on page 45) of the coffee machine.
2. [Insert the service key](#) (on page 89).
3. Perform the procedure [Flush mixers and brewer](#) (on page 48) several times.

If the message is still shown: Consult the service engineer (see [Service and support](#) on page 3).

6.1.31 Message: Water level too low

Message

Water level too low

Solution

Consult the service engineer (see [Service and support](#) on page 3).

6.1.32 Message: Wait, Heating boiler

Message

Wait, Heating boiler

Solution

Wait until the boiler is heated.

If the message is still shown after 10 minutes: Consult the service engineer (see [Service and support](#) on page 3).

6.1.33 Message: Waste bucket full / Empty waste bucket

Message *Waste bucket full / Empty waste bucket*

Solution Perform the following steps to solve the problem:

1. Empty the waste bucket (see [Clean waste bucket](#) on page 48).
 - If the message is still shown, remove the waste bucket and wait 6 seconds before placing it back.
 - If the message is still shown, check if the waste bucket detector switch is clean (check the [inside view](#) (on page 16) drawing for the location).
2. If a base cabinet is used, [Clean the waste bin in the base cabinet](#) (on page 51).

If the problem persists: Consult the service engineer (see [Service and support](#) on page 3).

6.1.34 Message: Water filter installed? / Water filter settings not set!

Message *Water filter installed? / Water filter settings not set!*

Solution Consult the service engineer (see [Service and support](#) on page 3).

6.1.35 Message: Ready, take your cup

Message *Ready, take your cup*

Cause The dispense of the beverage is finished.

Solution Remove the cup or jug.

Technical specifications

7.1 Standards and regulations

If the type plate inside the machine specifies any marking for conformity, standards or regulations, check the appendix for any additional information.

7.2 Type plate

The type plate is located inside the machine on the left side panel.

Type plate layout examples

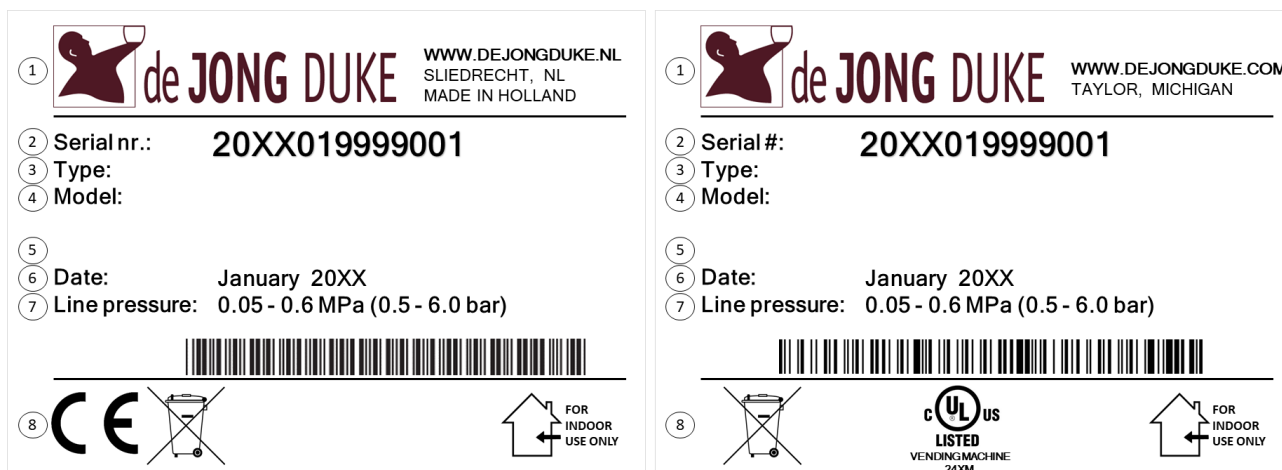

- | | |
|-------------------------------|---|
| 1. Manufacturer details | 5. Mains power specifications |
| 2. Serial number | 6. Date of production |
| 3. Model code | 7. Water connection specifications |
| 4. Model name / configuration | 8. Markings for conformity, disposal and use. For details, check the Appendix list (on page 104). |



NOTE

Data shown in the picture is for illustration purposes only.

7.3 Disassembly and recycling



The coffee machine contains recyclable materials. Dispose of the coffee machine in conformity with local laws and regulations.

7.4 Technical specifications

*Machine dimensions (± 0.39 in) and weight specifications ($\pm 10\%$)
Virtu CEC Medium Cabinet*

Height	34.45 in
Height with extended bean canister	40.16 in
Width	17.05 in
Depth	22.64 in
Depth door only	7.28 in
Weight (empty)	121.3 lb

Machine electrical specifications

Mains supply ($\pm 10\%$)	Refer to the type plate (on page 99) inside the coffee machine for the correct values.
Frequency ($\pm 2\%$)	
Max. capacity	

Machine water specification

Water pressure	
Minimum pressure	7.3 psi
Maximum pressure	87 psi
Water connection	$\frac{3}{4}$ BSP connection
Quality of water	
Hardness	5-7° dH (German standard) 8-12 fH (French standard)
pH Value	approx. 7
Temperature water	The incoming temperature may not be above 86°F
Main water connection	Between water tap and coffee machine an (electronic) waterlock needs to be connected

Machine hot water pressure system

Pressure Systems Safety Regulations 2000 (PSSR)	Pressure boiler
Vessel category	SEP
Operating pressure (standard)	atmospheric
Nominal operating pressure (dynamic) pumped	0-145.0 psi
Test pressure (design)	348.1 psi
Pressure safety device	174.0 psi
Nominal operating temperature (Max. operating)	197.6 \pm 18 °F
Safety device cutoff temperature (clixon)	230 \pm 9 °F

Machine ambient temperature specifications

When in storage	+ 50 °F ~ + 122 °F
When in use	+ 41 °F ~ + 104 °F

Machine sound pressure

Standby	< 20 dB(A)
---------	------------

7.5 Cup and jug sizes

Cup and jug dimensions Virtu (medium model)

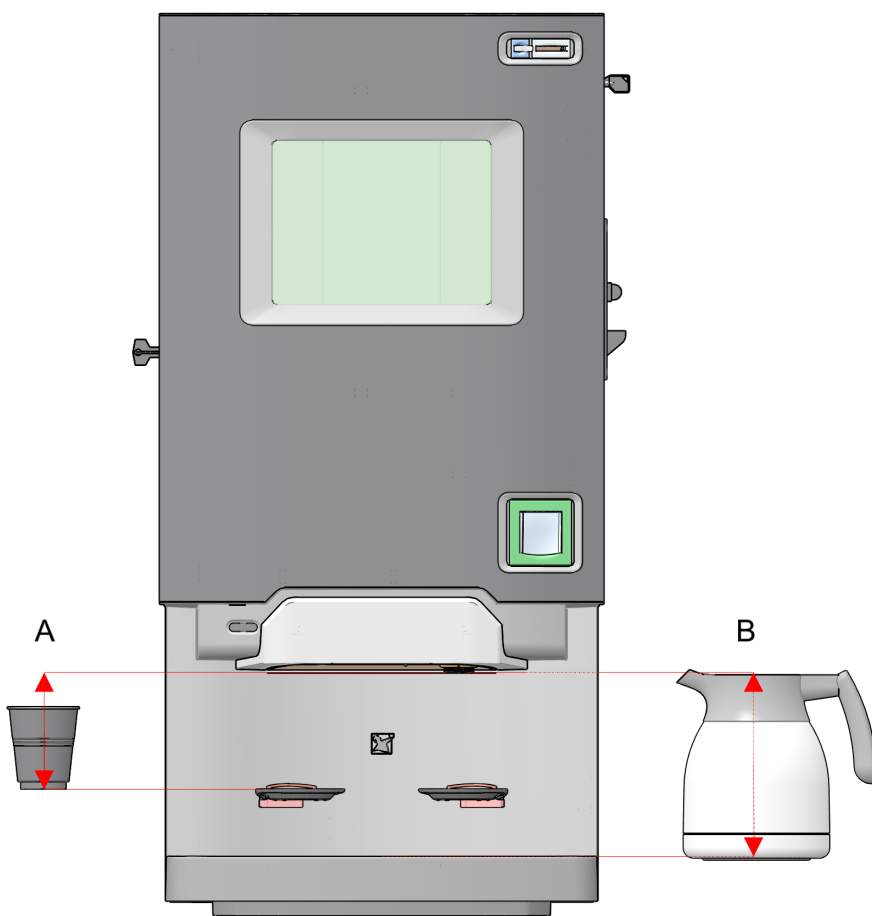

A. Cups

Maximum cup height (*)	4.33 in
Maximum cup diameter	3.35 in

B. Jugs

Maximum jug height	7.09 in
Maximum jug diameter	5.31 in

(*) The height of the cup stand is fixed and depends on specifications during ordering.

7.6 Manufacturer contact information



De Jong DUKE

Postbus 190

3360 AD SLIEDRECHT

The Netherlands



+31 (0) 184 209 767

www.dejongduke.nl



support@dejongduke.nl



De Jong DUKE North America

12680 Delta Street

Taylor, MI, 48180

U.S.A.



+1 734 403 1708

www.dejongduke.com



support@dejongduke.com

Service and support

For questions, service and ingredients for this coffee machine: Consult the service engineer (see [Service and support](#) on page 3).

Appendix

8.1 Appendix list

Information related to this document and the coffee machine:

- Declaration of conformity (see [Declaration of conformity Virtu](#) on page 105).

8.2 Declaration of conformity Virtu

EU DECLARATION OF CONFORMITY

(In accordance with EN ISO/IEC 17050-1)



THIS DECLARATION OF CONFORMITY IS ISSUED UNDER THE SOLE RESPONSIBILITY OF:

Name and address of manufacturer: **De Jong DUKE
Marisstraat 2
3364 AZ Sliedrecht
Netherlands**

Product identification:

- | | | | |
|----------------------|----------------------|----------------------|-----------------------|
| ▪ Virtu 10 00 Series | ▪ Virtu 40 00 Series | ▪ Virtu 70 00 Series | ▪ Virtu 18.000 Series |
| ▪ Virtu 20 00 Series | ▪ Virtu 50 00 Series | ▪ Virtu 80 00 Series | ▪ Virtu 19.000 Series |
| ▪ Virtu 30 00 Series | ▪ Virtu 60 00 Series | ▪ Virtu 90 00 Series | |

THE PRODUCTS MENTIONED IN THIS DECLARATION ARE IN CONFORMITY WITH:

EU Community
Legislation:

Restriction of Hazardous Substances (RoHS) Directive 2011/65/EU [OJEU L174/88-110, 01.07.2011]
Electromagnetic Compatibility (EMC) Directive 2014/30/EU [OJEU L96/79-106, 29.03.2014]
Ecodesign energy-related products Directive 2009/125/EC [OJEU L285/10-35, 31.10.2009]
Low Voltage Directive (LVD) 2014/35/EU [OJEU L96/357-374, 29.03.2014]
The Electromagnetic Compatibility Regulations 2016 (UK SI 2016 No. 1091)
The Ecodesign for Energy-Related Products Regulations 2010 (UK SI 2010 No. 2617)
The Electrical Equipment (Safety) Regulations 2016 (UK SI 2016 No. 1101)
The RoHS Regulations 2012 (UK SI 2012 No. 3032)

Harmonised standards:

Safety of electrical equipment
EN 60335-1:2012 +A1:2019 +A2:2019 + A11:2014 + A13:2017 + A14:2019 + A15:2021 + AC:2014
EN 60335-2-75:2004 + A1:2005 + A2:2008 + A11:2006 + A12:2010
EN IEC 60335-1:2020
EN IEC 60335-2-75:2012

Electromagnetic Compatibility (EMC)
EN 55014-1:2017 + A11:2020
EN 55014-2:1997 + A1:2001 + A2:2008 + AC:1997
EN IEC 55014-1:2021
EN IEC 55014-2:2021

Restricted substances in electrical products
EN IEC 63000:2018

Ecodesign, Energy performance
EN 50564:2011

SIGNED FOR AND ON BEHALF OF:

Place and date of issue: **Sliedrecht, September 26, 2023**

Signature:

Name, position: **Rob Bastinck, Managing Director**

Company name: **de Jong DUKE**

